

**PROJECT:**

**ELECTRICAL DESIGN OF CAMP 4EX PHC  
(1ST PHASE)**

**Location:**



















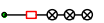

Camp 4-ex, Ukhiya, Cox's Bazar.

**Date of Submission:**

December 04, 2025

**Drawing Title:**

**ELECTRICAL DRAWING**

LEGEND		
SYMBOL	ABBREVIATION	DESCRIPTION
	TL	TUBE LIGHT 20 W (1200mm)
	CF	CEILING FAN (56")
	WL	WALL LIGHT (24 W) (LED BULB)
	AC	AC INDOOR UNIT (SPLIT TYPE)
	SB	SWITCH BOARD (H:48")
	CL	12W CEILING LIGHT (ROUND)
	QS	13 A 6 PIN COMBINE SOCKET (18" FROM FINISHED FLOOR)
	QM	20 A SOCKET (LINTEL LEVEL)
	CB	CIRCUIT BREAKER
		PHASE INDICATOR
	SDB	SUB DISTRIBUTION BOARD
	MDB	MAIN DISTRIBUTION BOARD
	SMDB	SUB MAIN DISTRIBUTION BOARD
	WMF	WALL MOUNTED FAN
	EX	EXHAUST FAN (12")
	FL	FLOOD LIGHT 50 W
	PL	PANEL LIGHT 24 W (300mmX300mm)
		LIGHTING CONDUIT
		POWER CONDUIT
		SWITCH CONDUIT
	CF	CEILING FAN 36"

CLIENT: UNHCR	PROJECT NAME: ELECTRICAL DESIGN OF CAMP 4EX PHC (1ST PHASE)	PARTICULARS:	NAME:	SIGNATURE:	DRAWING TITLE: LEGEND	REVISION NO. DATE & TIME DESCRIPTION	CONSULTANT:	-NOTES- THIS DRAWINGS SHALL BE READ IN CONJUNCTION WITH RELEVANT ARCHITECTURAL, PLUMBING, ELECTRICAL AND MECHANICAL DRAWINGS	-COPYRIGHT-	REMARKS	SHEET NO: E-01
PROJECT ADDRESS: UKHIYA, COX'S BAZAR	SCALE: NOT IN SCALE				DATE: 04-DEC-2025	01. - - 02. - - 03. - - 04. - - 05. - -					



# Proposed Electrical Layout for Health, Nutrition & PHC at Camp-4X

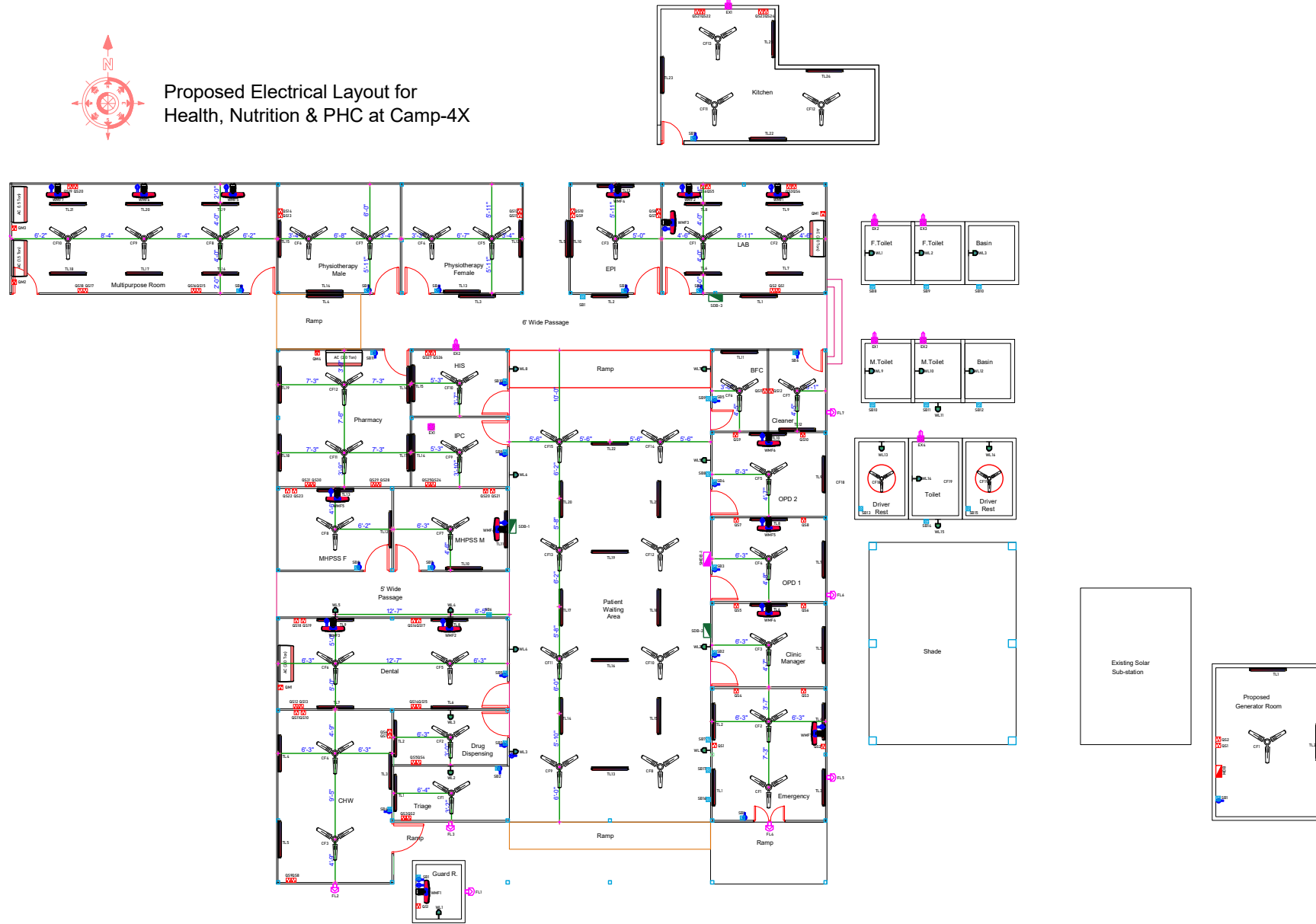

CLIENT:	PROJECT NAME:	PARTICULARS:	NAME:	SIGNATURE:	DRAWING TITLE:	REVISION:	CONSULTANT:	-NOTES-	-COPYRIGHT-	REMARKS:	SHEET NO.:
UNHCR	ELECTRICAL DESIGN OF CAMP 4EX PHC (1ST PHASE)				ELECTRICAL LAYOUT PLAN	NO. DATE & TIME: DESCRIPTION		THIS DRAWINGS SHALL BE READ IN CONJUNCTION WITH RELEVANT ARCHITECTURAL, PLUMBING, ELECTRICAL AND MECHANICAL DRAWINGS			E-02
PROJECT ADDRESS:	SCALE:				DATE:	01. - - -					
UKHIYA, COX'S BAZAR	NOT IN SCALE				04-DEC-2025	02. - - -					
						03. - - -					
						04. - - -					
						05. - - -					



# Proposed Light Conduit Layout for Health, Nutrition & PHC at Camp-4X

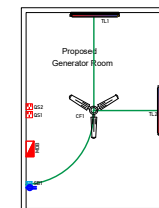
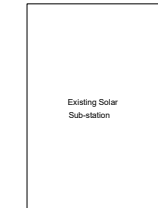
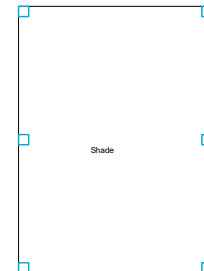
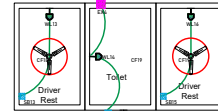
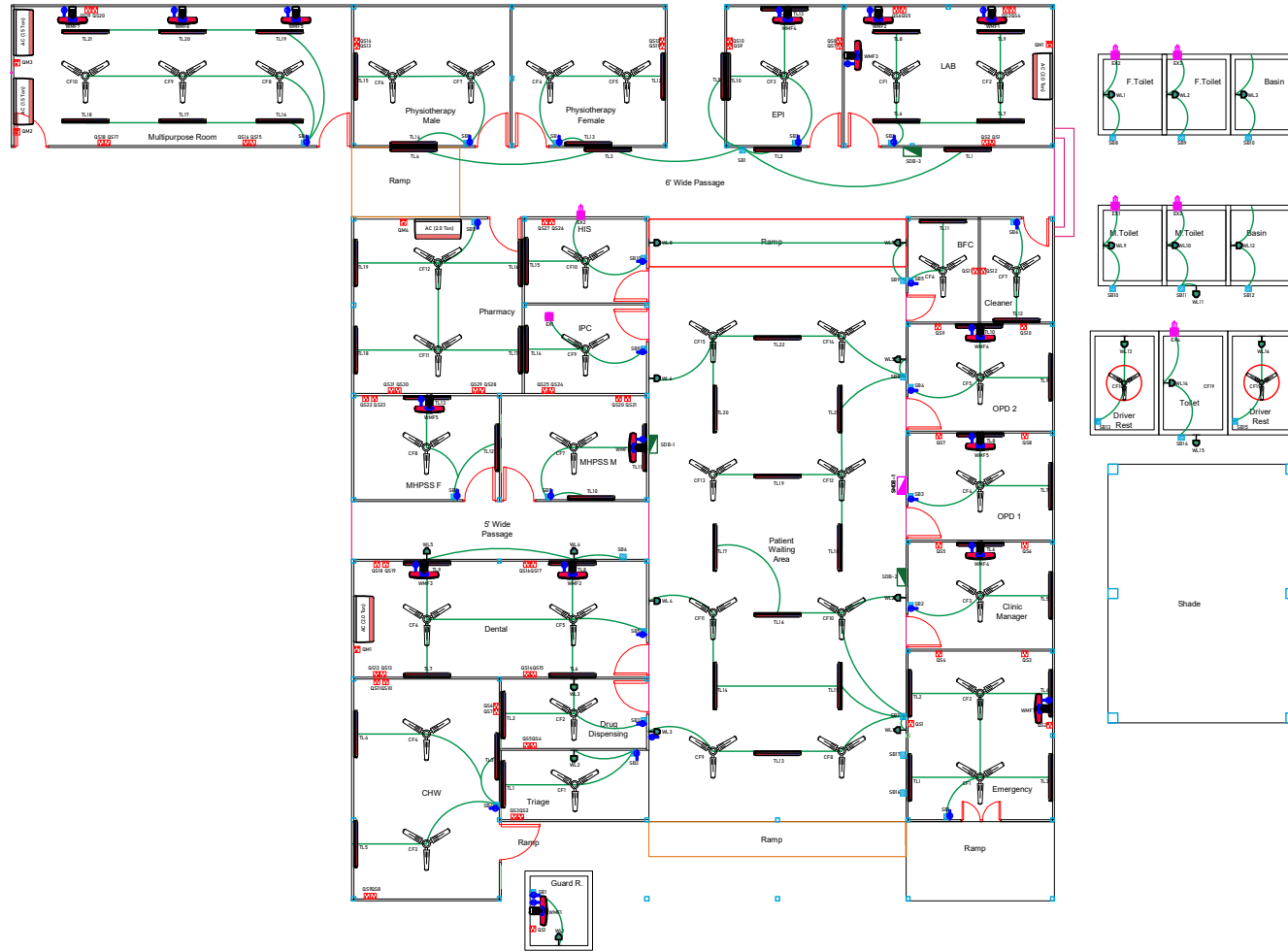
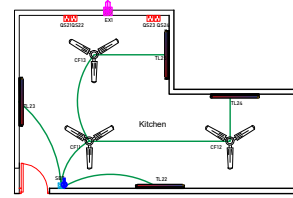

CLIENT : UNHCR	PROJECT NAME: ELECTRICAL DESIGN OF CAMP 4EX PHC (1ST PHASE)	PARTICULARS	NAME	SIGNATURE:	DRAWING TITLE: LIGHT CONDUIT PLAN	REVISION			CONSULTANT:	NOTES THIS DRAWINGS SHALL BE READ IN CONJUNCTION WITH RELEVANT ARCHITECTURAL, PLUMBING, ELECTRICAL AND MECHANICAL DRAWINGS	-COPYRIGHT-	REMARKS	SHEET NO: E-03
	SCALE: NOT IN SCALE				DATE: 04-DEC-2025	NO.	DATE & TIME:	DESCRIPTION					
PROJECT ADDRESS: UKHYIA, COX'S BAZAR						01.							
						02.							
						03.							
						04.							
						05.							



# Proposed Power Conduit Layout for Health, Nutrition & PHC at Camp-4X

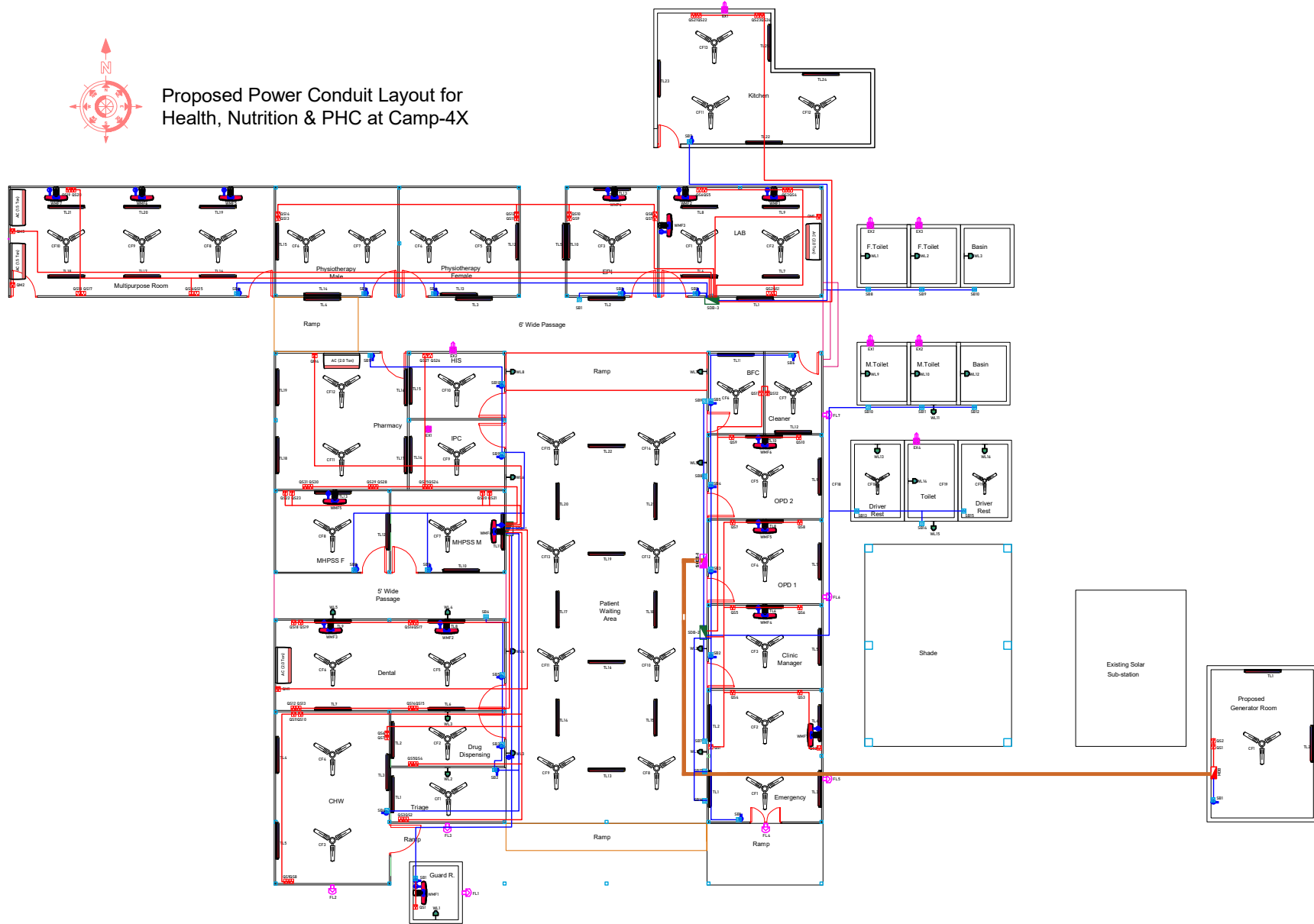

CLIENT	PROJECT NAME	PARTICULARS	NAME	SIGNATURE	DRAWING TITLE	REVISION	CONSULTANT	NOTES	COPYRIGHT	REMARKS	SHEET NO.
UNHCR	ELECTRICAL DESIGN OF CAMP 4EX PHC (1ST PHASE)				POWER CONDUIT PLAN	NO. DATE & TIME DESCRIPTION		THIS DRAWINGS SHALL BE READ IN CONJUNCTION WITH RELEVANT ARCHITECTURAL, PLUMBING, ELECTRICAL AND MECHANICAL DRAWINGS			E-04
PROJECT ADDRESS	SCALE				DATE	01. - - -					
UKHIYA, COX'S BAZAR	NOT IN SCALE				04-DEC-2025	02. - - -					
						03. - - -					
						04. - - -					
						05. - - -					

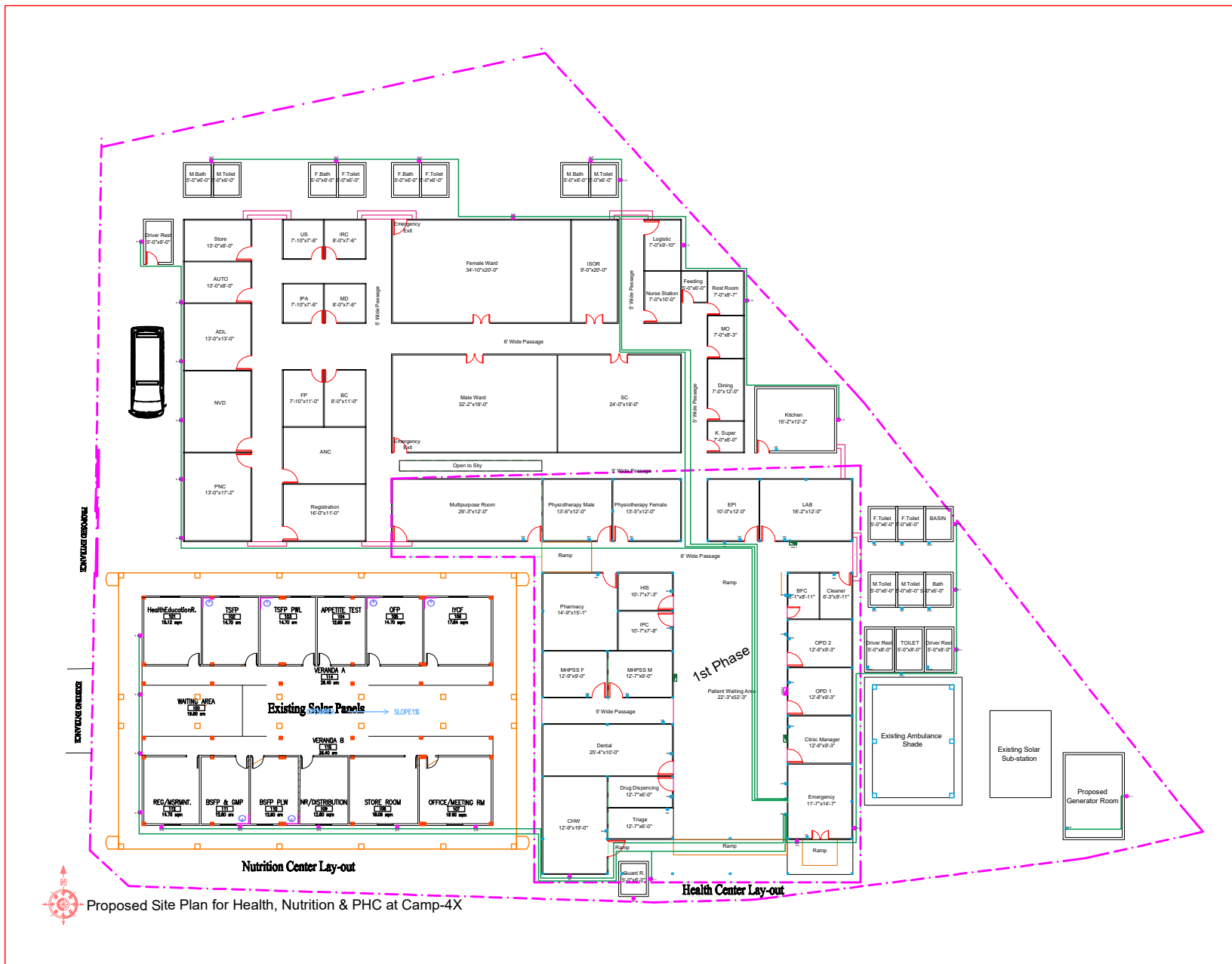

CLIENT :	PROJECT NAME :	PARTICULARS :	NAME :	SIGNATURE :	DRAWING TITLE :	REVISION :	CONSULTANT :	NOTES :	COPYRIGHT :	REMARKS :	SHEET NO. :
UNHCR	ELECTRICAL DESIGN OF CAMP 4EX PHC (1ST PHASE)				FLOOD LIGHT LAYOUT	NO. DATE & TIME: DESCRIPTION		THIS DRAWINGS SHALL BE READ IN CONJUNCTION WITH RELEVANT ARCHITECTURAL, PLUMBING, ELECTRICAL AND MECHANICAL DRAWINGS			E-05
PROJECT ADDRESS :	SCALE :				DATE :	01. - - -					
UKHIYA, COX'S BAZAR	NOT IN SCALE				04-DEC-2025	02. - - -					
						03. - - -					
						04. - - -					
						05. - - -					

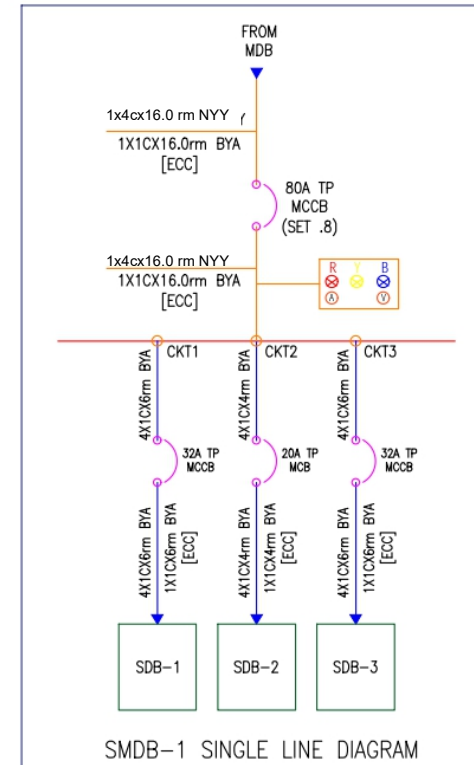
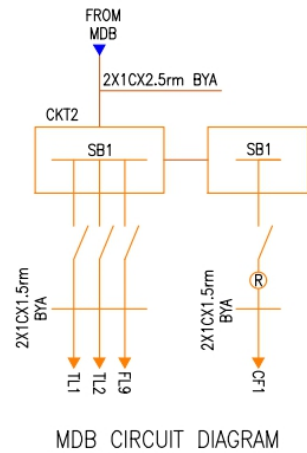
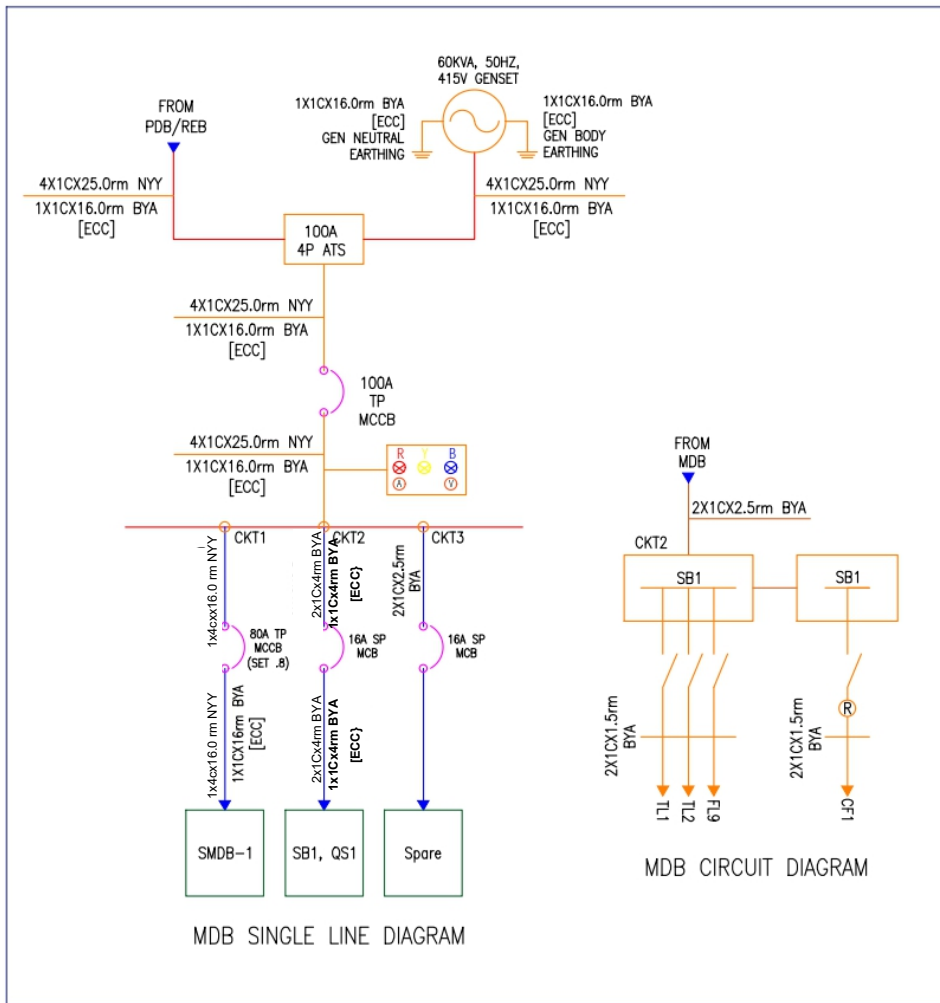

CLIENT UNHCR PROJECT ADDRESS UKHAYA, COX'S BAZAR	PROJECT NAME <b>ELECTRICAL DESIGN OF CAMP (EX PHC (1ST PHASE))</b> SCALE NOT IN SCALE	PNR NO./A/S   	NAME   	SIGNATURE   	DRAWING TITLE <b>MDB and SMDB-1 SLD</b> DATE 04-DEC-2025	REVISION <table border="1"> <thead> <tr> <th>NO.</th> <th>DATE &amp; TIME</th> <th>DESCRIPTION</th> </tr> </thead> <tbody> <tr> <td>01</td> <td>-</td> <td>-</td> </tr> <tr> <td>02</td> <td>-</td> <td>-</td> </tr> <tr> <td>03</td> <td>-</td> <td>-</td> </tr> <tr> <td>04</td> <td>-</td> <td>-</td> </tr> <tr> <td>05</td> <td>-</td> <td>-</td> </tr> </tbody> </table>	NO.	DATE & TIME	DESCRIPTION	01	-	-	02	-	-	03	-	-	04	-	-	05	-	-	ED-SUPPLIER   	-TITLE- THIS DRAWING'S SHALL BE READ IN CONJUNCTION WITH RELEVANT ARCHITECTURAL, PLUMBING, ELECTRICAL AND MECHANICAL DRAWINGS	COPYRIGHT   	REMARKS   	SHEET NO <b>E-06</b>
NO.	DATE & TIME	DESCRIPTION																											
01	-	-																											
02	-	-																											
03	-	-																											
04	-	-																											
05	-	-																											

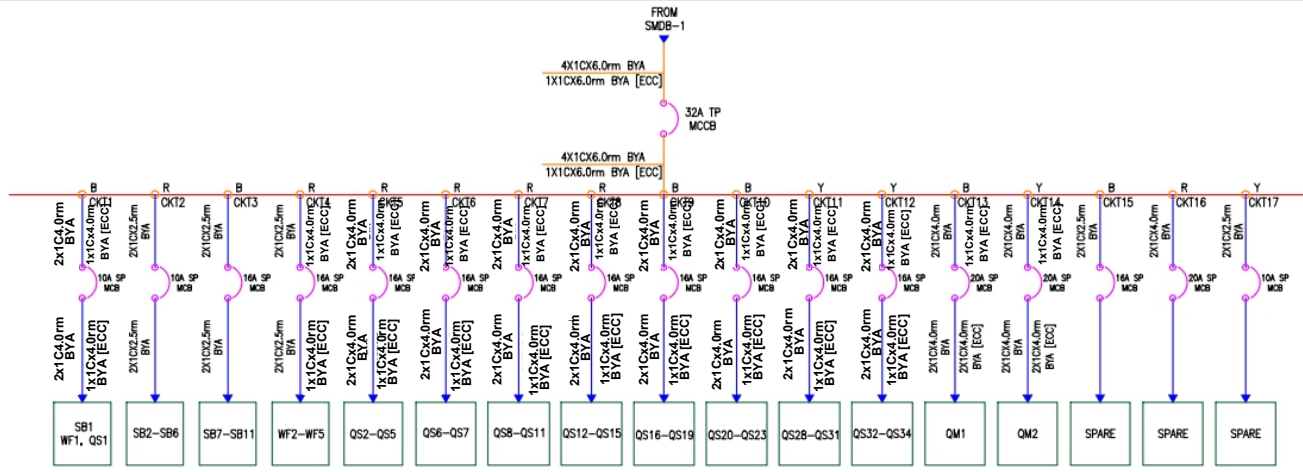

SDB-1 SINGLE LINE DIAGRAM

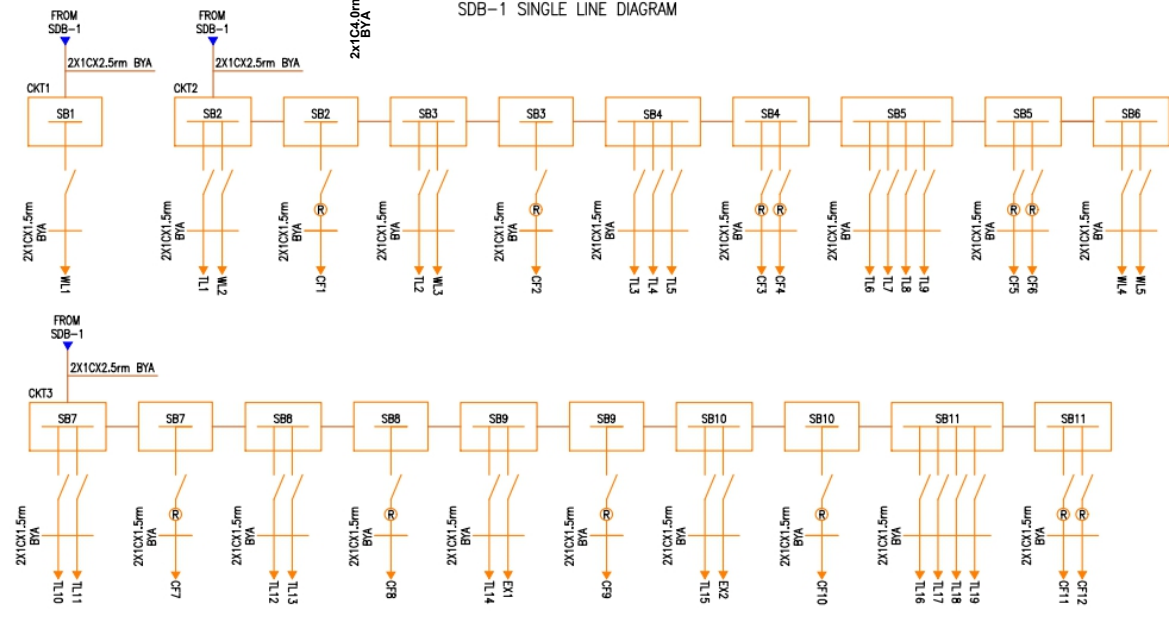

SDB-1 CIRCUIT DIAGRAM

CLIENT UNHCR	PROJECT NAME ELECTRICAL DESIGN OF CAMP 4EX PHC (1ST PHASE)	PROJECT ADDRESS UKHUYA, COX'S BAZAR	DATE 04-DEC-2025	REVISIONS NO. DATE & TIME DESCRIPTION	CD/DWG/REV	NOTES THIS DRAWING SHALL BE READ IN CONJUNCTION WITH RELEVANT ARCHITECTURAL, PLUMBING, ELECTRICAL AND MECHANICAL DRAWINGS	COPYRIGHT	REVISIONS	SHEET NO E-07
	SCALE NOT IN SCALE								

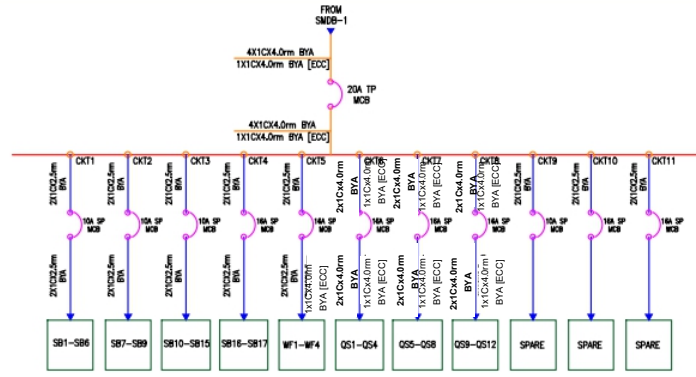

SDB-2 SINGLE LINE DIAGRAM

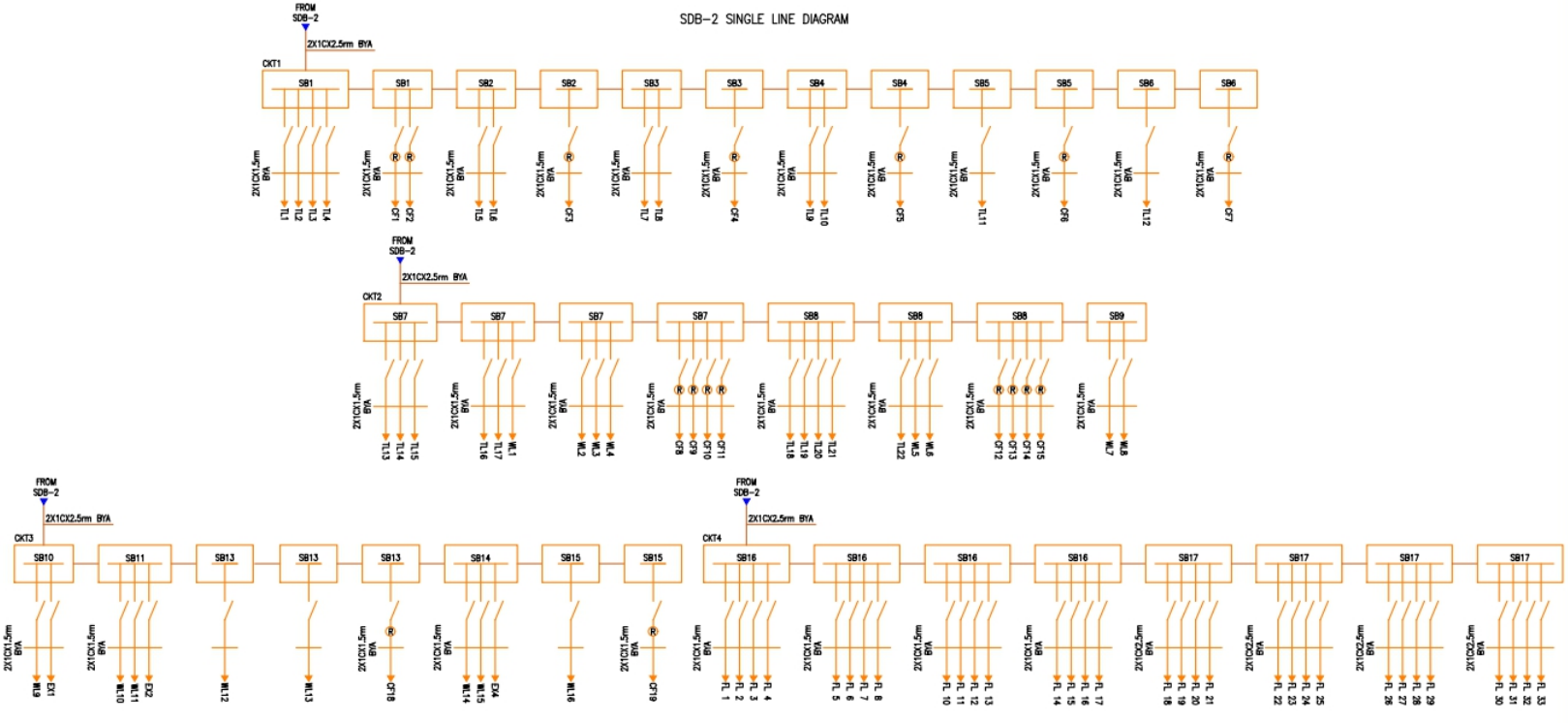

SDB-2 CIRCUIT DIAGRAM

CLIENT UNHCR	PROJECT NAME <b>ELECTRICAL DESIGN OF CAMP          4EX PHC (1ST PHASE)</b>	PARTICULARS	NAME	SIGNATURE	DRAWING FILE <b>SDB-2 SLD &amp; CIRCUIT DIAGRAM</b>	REVISION NO. DATE & TIME DLSR/PP/SDH	CONTRACT NO.	NOTES THIS DRAWING SHALL BE READ IN CONJUNCTION WITH RELEVANT ARCHITECTURAL, PLUMBING, ELECTRICAL AND MECHANICAL DRAWINGS	COPYRIGHT	REMARKS	SHEET NO. <b>E-08</b>
	PROJECT ADDRESS UKHAYA, COX'S BAZAR				SCALE NOT IN SCALE	DATE 04-DEC-2025					



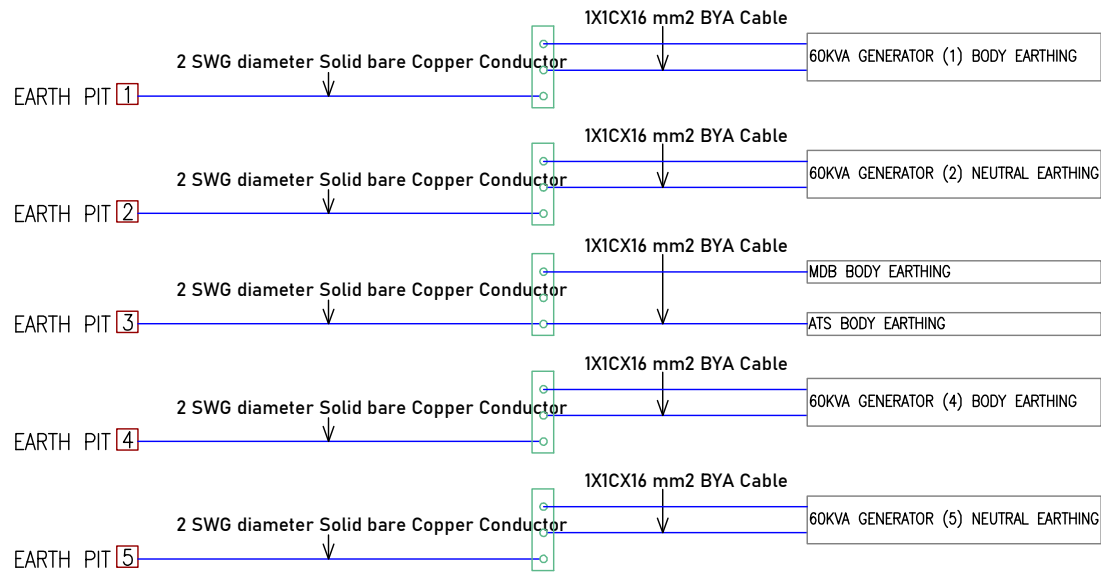
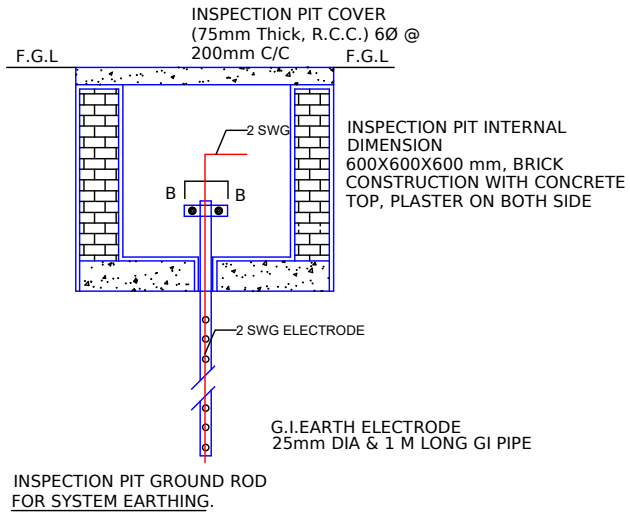

*Earthing Layout Drawing*

CLIENT UNHCR	PROJECT NAME ELECTRICAL DESIGN OF CAMP 4EX PHC (1ST PHASE)	PARTICULARS	NAME	SIGNATURE	DRAWING TITLE EARTHING DETAILS	REVISION NO. DATE & TIME DESCRIPTION	CONSULTANT	NOTES THIS DRAWINGS SHALL BE READ IN CONJUNCTION WITH RELEVANT ARCHITECTURAL, PLUMBING, ELECTRICAL AND MECHANICAL DRAWINGS	COPYRIGHT	REMARKS	SHEET NO. E-10
PROJECT ADDRESS UKHIYA, COX'S BAZAR	SCALE NOT IN SCALE				DATE 04-DEC-2025	01. - - 02. - - 03. - - 04. - - 05. - -					

**PROJECT:**

**ELECTRICAL DESIGN OF CAMP 4-EX PHC  
(1ST PHASE)**

**Location:**

Camp 4-ex, Ukhiya, Cox's Bazar.

**Date of Submission:**

December 04, 2025

**Drawing Title:**

LPS DRAWING

# RISK INDEX ASSESSMENT AS PER BNBC 2006

INDEX	TITLE	DETAILS	POINTS
A	USE OF STRUCTURE	Office block	7
B	TYPE OF CONTRUCTION	Metal Roof	5
C	CONTENTS OR CONSEQUENTIAL EFFECTS	Not containing valuable materials	2
D	DEGREE OF ISOLATION	Structure located in a large area having structures or trees of similar or greater height, e.g. a large town or forest	2
E	TYPE OF TERRAIN	Hilly terrain	6
F	HIGHT OF STRUCTURE	Up to 9 m	2
G	LIGHTNING PREVALENCE	Over 21	21
<b>THE SUM OF INDEX</b>			<b>45</b>
<b>MARGINAL RISK INDEX</b>			<b>40</b>
<b>REMARKS</b>			<b>LIGHTNING PROTECTION IS REQUIRED</b>

CLIENT:	PROJECT NAME:	PARTICULARS:	NAME:	SIGNATURE:	DRAWING TITLE:	REVISION:	CONSULTANT:	NOTES:	COPYRIGHT:	REMARKS:	SHEET NO.:
UNHCR	ELECTRICAL DESIGN OF CAMP 4EX PHC (1ST PHASE)				RISK INDEX	NO. DATE & TIME DESCRIPTION		THIS DRAWINGS SHALL BE READ IN CONJUNCTION WITH RELEVANT ARCHITECTURAL PLUMBING, ELECTRICAL AND MECHANICAL DRAWINGS			
PROJECT ADDRESS:	SCALE:				DATE:	01. - -					
UKHIYA, COX'S BAZAR	NOT IN SCALE				04-DEC-2025	02. - -					<b>LPS-01</b>
						03. - -					
						04. - -					
						05. - -					



# Proposed Electrical Layout for Health, Nutrition & PHC at Camp-4X

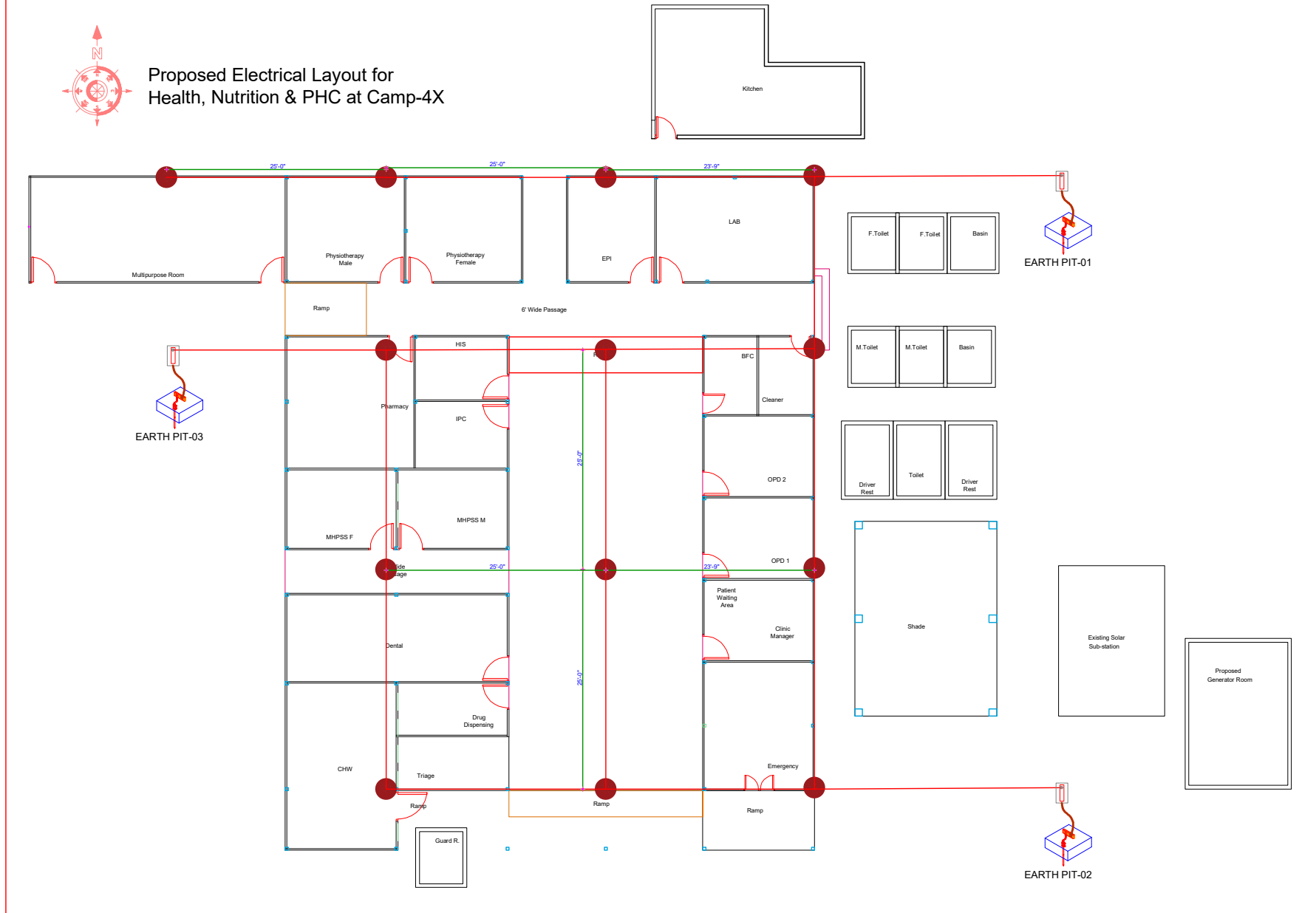

CLIENT: UNHCR	PROJECT NAME: <b>ELECTRICAL DESIGN OF CAMP 4EX PHC (1ST PHASE)</b>	PARTICULARS:	NAME:	SIGNATURE:	DRAWING TITLE: <b>LPS LAYOUT</b>	REVISION		CONSULTANT:	NOTES: THIS DRAWINGS SHALL BE READ IN CONJUNCTION WITH RELEVANT ARCHITECTURAL, PLUMBING, ELECTRICAL AND MECHANICAL DRAWINGS	COPYRIGHT:	REMARKS:	SHEET NO: <b>LPS-02</b>
	SCALE: NOT IN SCALE				DATE: 04-DEC-2025	NO.	DATE & TIME					
PROJECT ADDRESS: UKHIYA, COX'S BAZAR						01.						
						02.						
						03.						
						04.						
						05.						

# DESIGN STANDARD : NFPA 780, EDITION 2014

LEGEND	
Symbol	Explanation
	Air Terminal
	Roof & Down Conductor
	Grounding Electrode

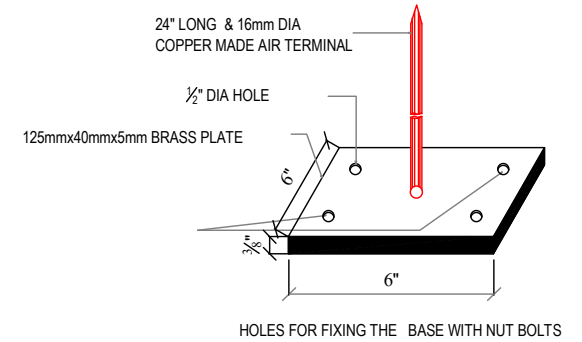
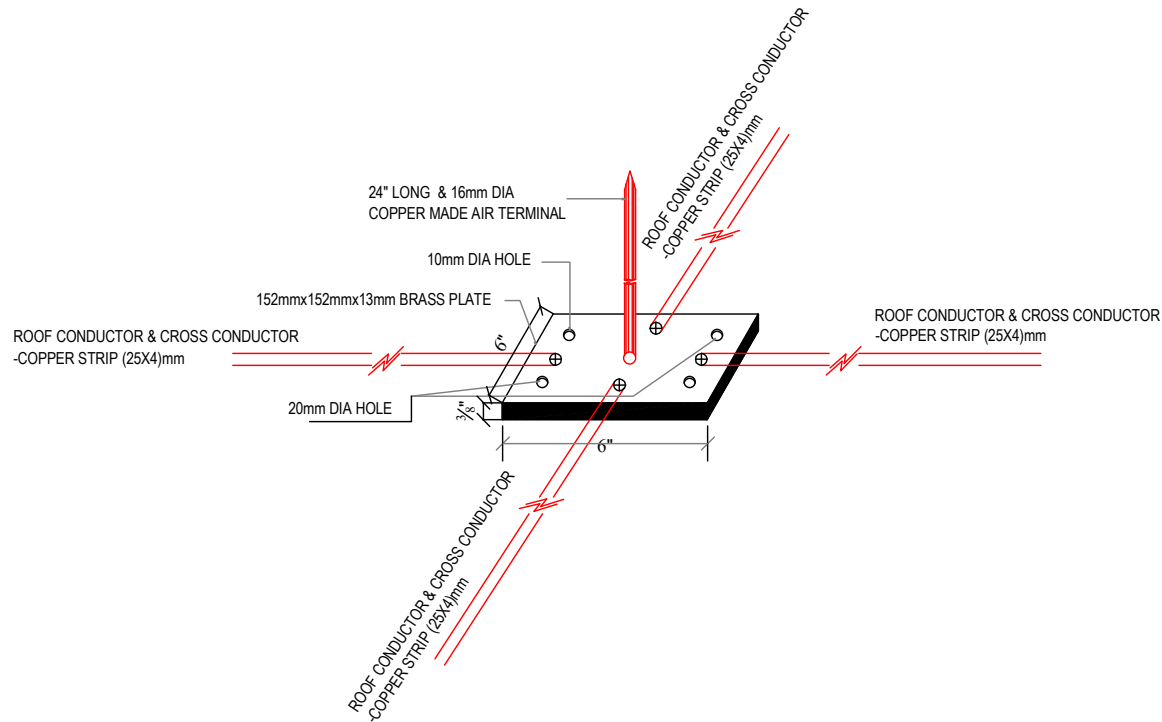
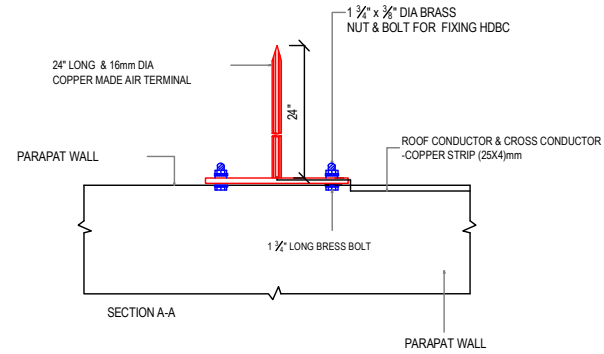

CLIENT: UNHCR	PROJECT NAME: ELECTRICAL DESIGN OF CAMP 4EX PHC (1ST PHASE)	PARTICULARS	NAME:	SIGNATURE:	DRAWING TITLE: AIR TERMINAL DETAILS	REVISION	CONSULTANT:	-NOTES- THIS DRAWINGS SHALL BE READ IN CONJUNCTION WITH RELEVANT ARCHITECTURAL, PLUMBING, ELECTRICAL AND MECHANICAL DRAWINGS	-COPYRIGHT-	REMARKS	SHEET NO: LPS-03
PROJECT ADDRESS: UKHIYA, COX'S BAZAR	SCALE: NOT IN SCALE				DATE: 04-DEC-2025	NO. DATE & TIME DESCRIPTION 01. - - 02. - - 03. - - 04. - - 05. - -					

**DESIGN STANDARD : NFPA 780, EDITION 2014**

LEGEND	
Symbol	Explanation
	Air Terminal
	Roof & Down Conductor
	Grounding Electrode

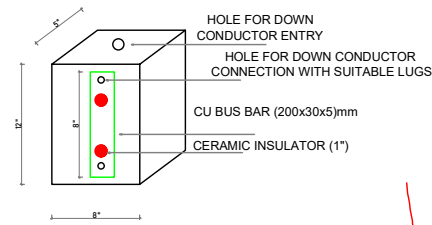

**EARTH RESISTANCE TEST POINT**

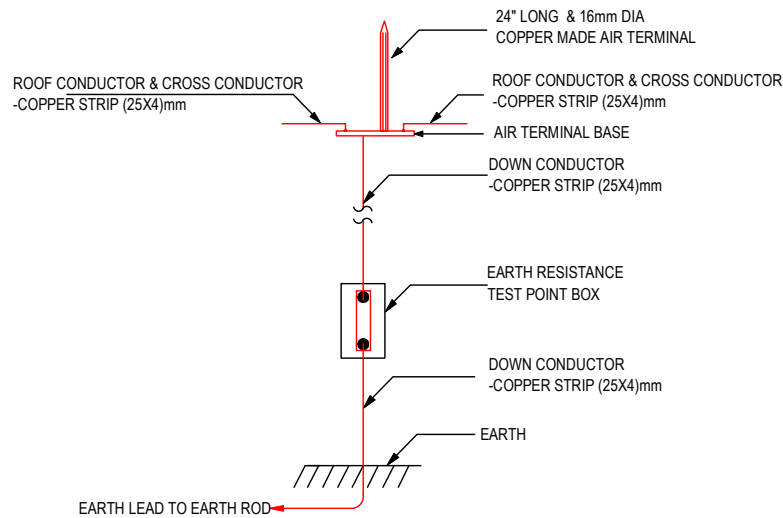
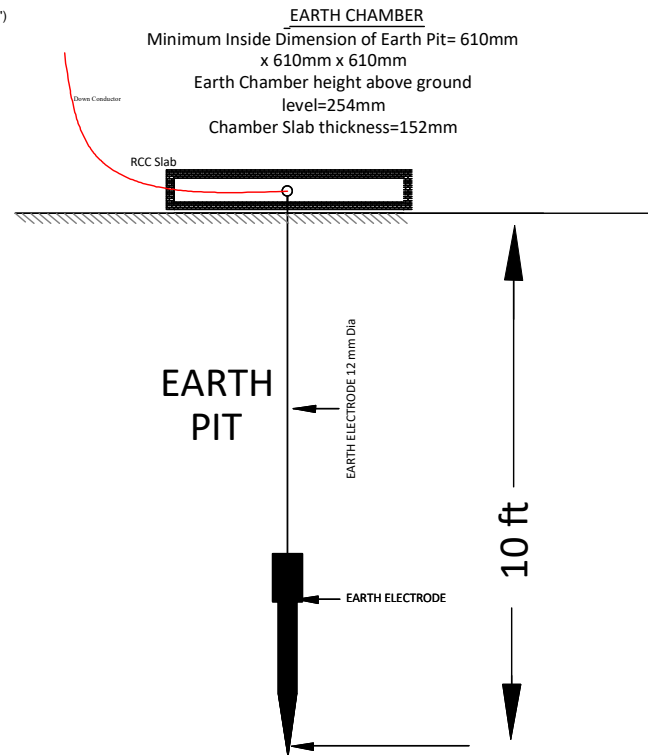

CLIENT UNHCR	PROJECT NAME ELECTRICAL DESIGN OF CAMP 4EX PHC (1ST PHASE)	PARTICULARS	NAME	SIGNATURE	DRAWING TITLE LPS EARTHING DETAILS	REVISION NO. DATE & TIME DESCRIPTION	CONSULTANT	NOTES THIS DRAWINGS SHALL BE READ IN CONJUNCTION WITH RELEVANT ARCHITECTURAL, PLUMBING, ELECTRICAL AND MECHANICAL DRAWINGS	COPYRIGHT	REMARKS	SHEET NO. LPS-04
PROJECT ADDRESS UKHIYA, COX'S BAZAR	SCALE NOT IN SCALE				DATE 04-DEC-2025	01. - - 02. - - 03. - - 04. - - 05. - -					

**PROJECT:**

**ELECTRICAL DESIGN OF CAMP 4-EX PHC  
(1ST PHASE)**

**Location:**

Camp 4-ex, Ukhiya, Cox's Bazar.

**Date of Submission:**

December 04, 2025

**Drawing Title:**

**FIRE DRAWING**



# Proposed Electrical Layout for Health, Nutrition & PHC at Camp-4X

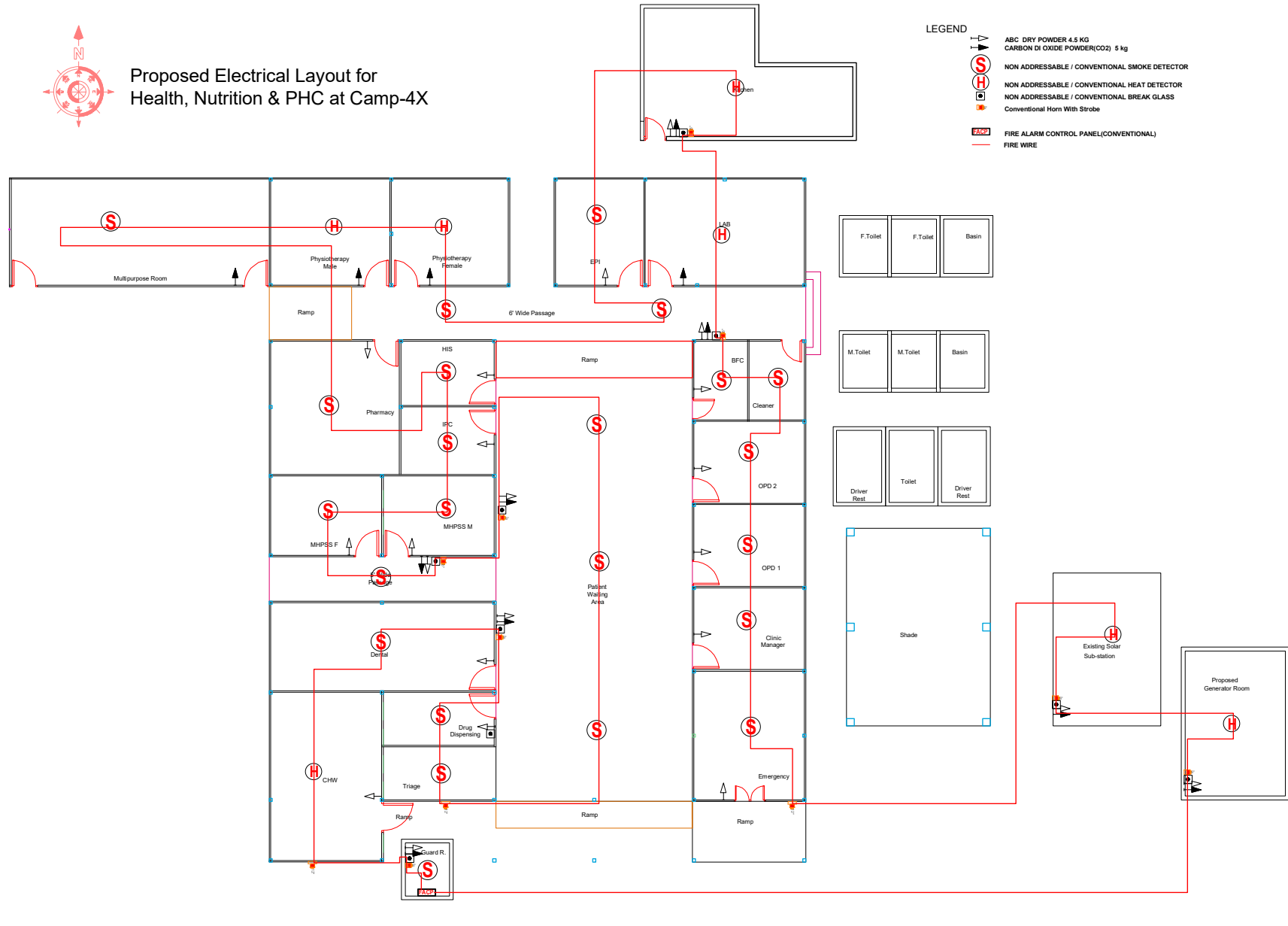

CLIENT: UNHCR	PROJECT NAME: ELECTRICAL DESIGN OF CAMP 4EX PHC (1ST PHASE)	PARTICULARS:	NAME:	SIGNATURE:	DRAWING TITLE: FIRE DESIGN	REVISION:	CONSULTANT:	NOTES: THIS DRAWINGS SHALL BE READ IN CONJUNCTION WITH RELEVANT ARCHITECTURAL, PLUMBING, ELECTRICAL AND MECHANICAL DRAWINGS	COPYRIGHT:	REMARKS:	SHEET NO: F-01
PROJECT ADDRESS: UKHIYA, COX'S BAZAR	SCALE: NOT IN SCALE				DATE: 04-DEC-2025	NO. DATE & TIME DESCRIPTION					
						01. - - -					
						02. - - -					
						03. - - -					
						04. - - -					
						05. - - -					