

PROJECT:

**ELECTRICAL DESIGN OF NFI DISTRIBUTION
POINT**

Location:





















Camp-26, Ukhiya, Cox's Bazar.

Date of Submission:

December 04, 2025

Drawing Title:

ELECTRICAL DRAWING

LEGEND		
SYMBOL	ABBREVIATION	DESCRIPTION
	TL	TUBE LIGHT 20 W (1200mm)
	CF	CEILING FAN (56")
	WL	WALL LIGHT (24 W) (LED BULB)
	AC	AC INDOOR UNIT (SPLIT TYPE)
	SB	SWITCH BOARD (H:48")
	CL	12W CEILING LIGHT (ROUND)
	QS	13 A 6 PIN COMBINE SOCKET (18" FROM FINISHED FLOOR)
	QM	20 A SOCKET (LINTEL LEVEL)
	CB	CIRCUIT BREAKER
		PHASE INDICATOR
	SDB	SUB DISTRIBUTION BOARD
	MDB	MAIN DISTRIBUTION BOARD
	SMDB	SUB MAIN DISTRIBUTION BOARD
	WMF	WALL MOUNTED FAN
	EX	EXHAUST FAN (12")
	FL	FLOOD LIGHT 50 W
	PL	PANEL LIGHT 24 W (300mmX300mm)
		LIGHTING CONDUIT
		POWER CONDUIT
		SWITCH CONDUIT
	CF	CEILING FAN 36"

CLIENT :	PROJECT NAME :	PARTICULARS :	NAME :	SIGNATURE :	DRAWING TITLE :	REVISION :	CONSULTANT :	NOTES :	COPYRIGHT :	REMARKS :	SHEET NO. :
UNHCR	ELECTRICAL DESIGN OF NFI DISTRIBUTION POINT				LEGEND	NO. DATE & TIME DESCRIPTION		THIS DRAWINGS SHALL BE READ IN CONJUNCTION WITH RELEVANT ARCHITECTURAL, PLUMBING, ELECTRICAL AND MECHANICAL DRAWINGS			E-01
PROJECT ADDRESS :	SCALE :				DATE :	01. - - -					
CAMP-26, UKHIYA, COX'S BAZAR	NOT IN SCALE				04-DEC-2025	02. - - -					
						03. - - -					
						04. - - -					
						05. - - -					

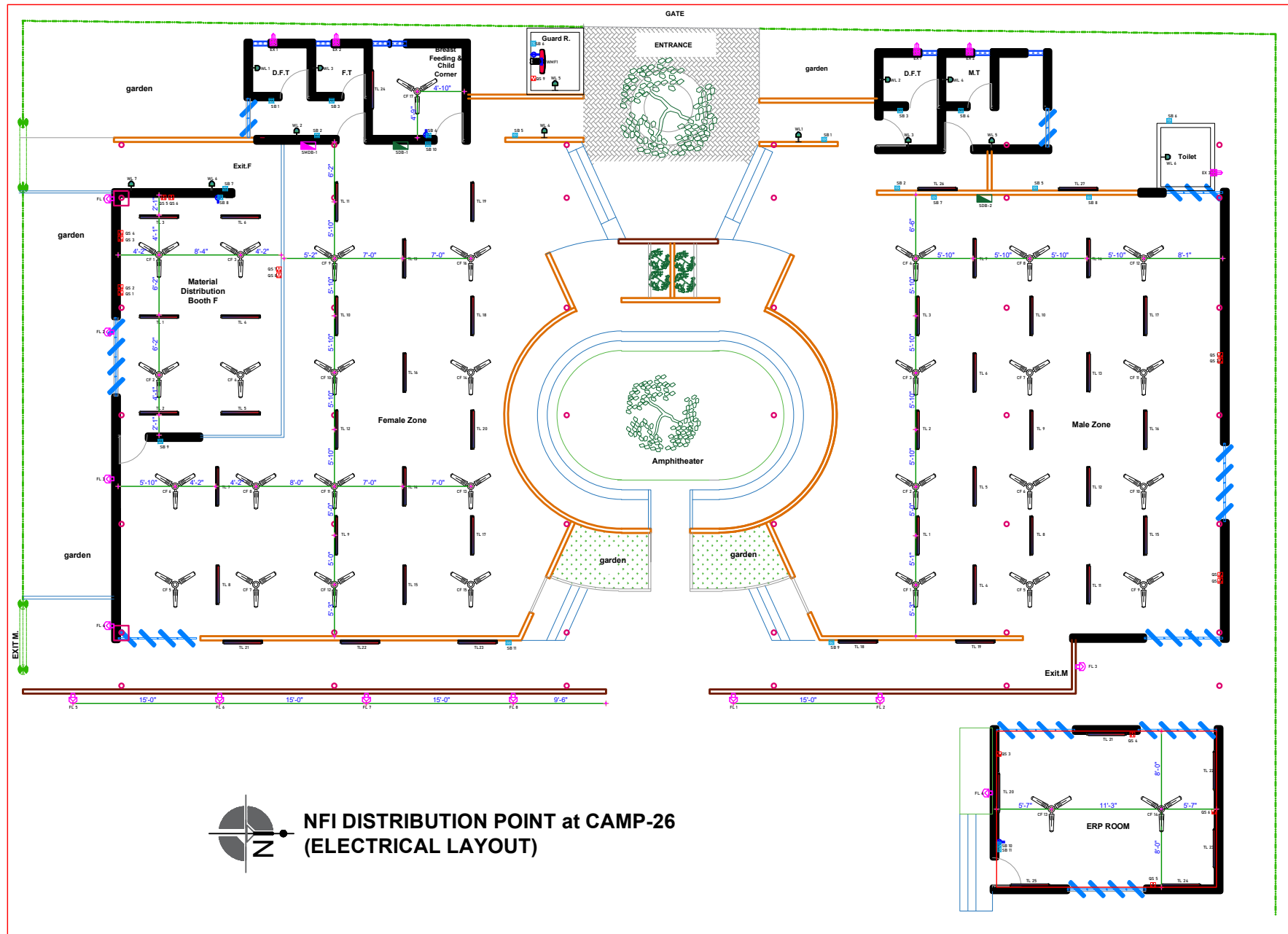

**NFI DISTRIBUTION POINT at CAMP-26
(ELECTRICAL LAYOUT)**

CLIENT: UNHCR	PROJECT NAME: ELECTRICAL DESIGN OF NFI DISTRIBUTION POINT	PARTICULARS:	NAME:	SIGNATURE:	DRAWING TITLE: ELECTRICAL LAYOUT PLAN	REVISION:	CONSULTANT:	NOTES: THIS DRAWINGS SHALL BE READ IN CONJUNCTION WITH RELEVANT ARCHITECTURAL, PLUMBING, ELECTRICAL AND MECHANICAL DRAWINGS	COPYRIGHT:	REMARKS:	SHEET NO: E-02
PROJECT ADDRESS: CAMP-26, UKHIYA, COX'S BAZAR	SCALE: NOT IN SCALE				DATE: 04-DEC-2025	NO. DATE & TIME: DESCRIPTION					
						01. - - -					
						02. - - -					
						03. - - -					
						04. - - -					
						05. - - -					

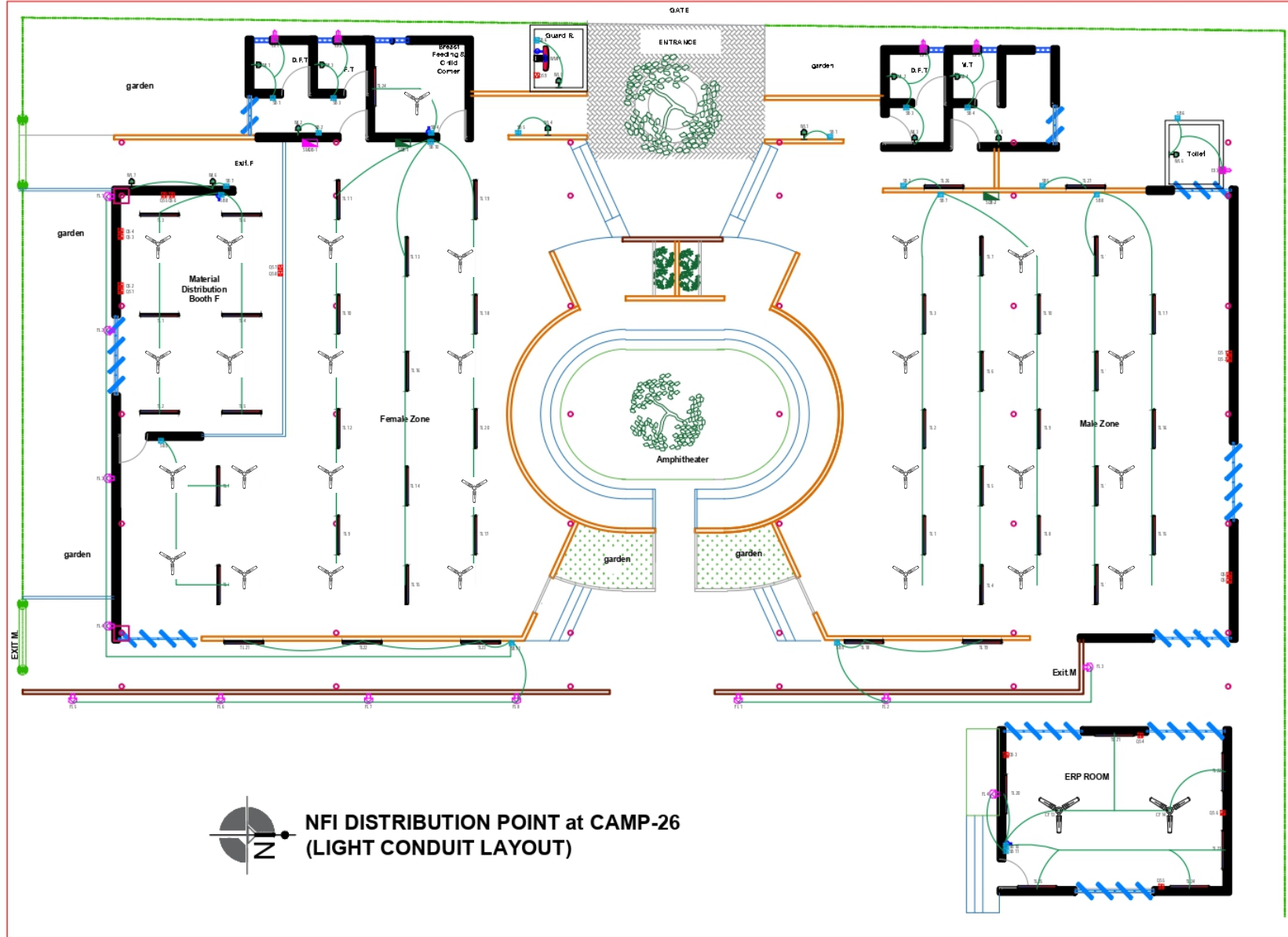

**NFI DISTRIBUTION POINT at CAMP-26
(LIGHT CONDUIT LAYOUT)**

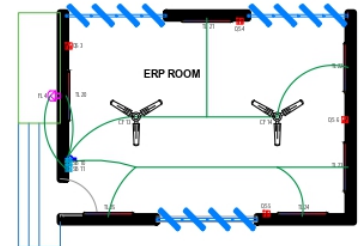

CLIENT UNHCR PROJECT ADDRESS CAMP-26, UKHUYA, COX'S BAZAR	PROJECT NAME ELECTRICAL DESIGN OF NFI DISTRIBUTION POINT	PROJECT NO. NAME SURNAME	DRAWING TITLE LIGHT CONDUIT PLAN	REVISION		ELECTRICAL -NO. OF- THIS DRAWING SHALL BE READ IN CONJUNCTION WITH RELEVANT ARCHITECTURAL, PLUMBING, ELECTRICAL AND MECHANICAL DRAWINGS	COPYRIGHT REMARKS	SHEET NO E-03
	SCALE NOT IN SCALE			DATE 04-DEC-2025	NO 01. 02. 03. 04. 05.			

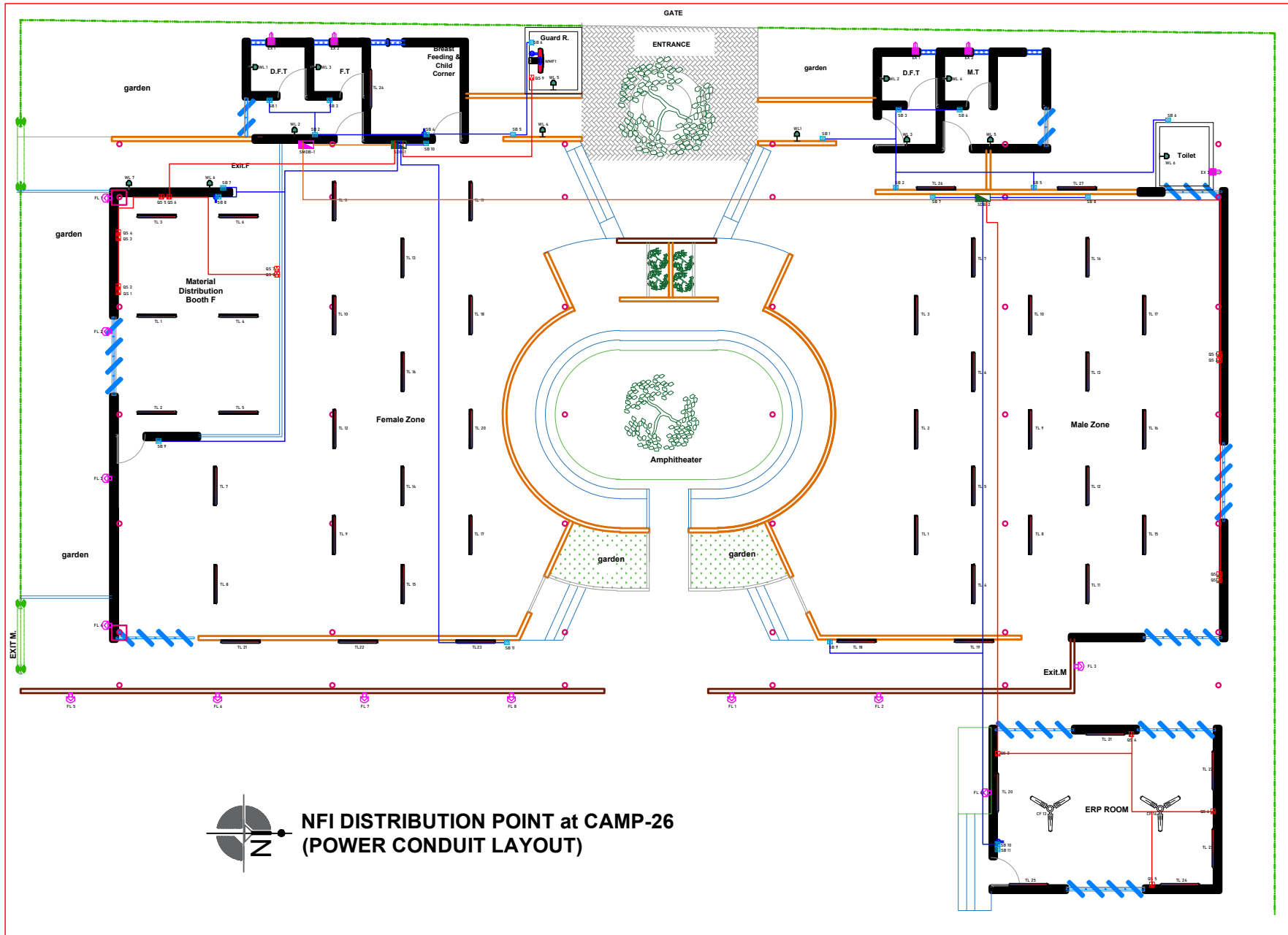

**NFI DISTRIBUTION POINT at CAMP-26
(POWER CONDUIT LAYOUT)**

CLIENT :	PROJECT NAME
UNHCR	ELECTRICAL DESIGN OF NFI DISTRIBUTION POINT
PROJECT ADDRESS :	SCALE:
CAMP-26, UKHIYA, COX'S BAZAR	NOT IN SCALE

PARTICULARS	NAME	SIGNATURE:

DRAWING TITLE	REVISION
POWER CONDUIT PLAN	NO. DATE & TIME DESCRIPTION
DATE:	01. - - -
04-DEC-2025	02. - - -
	03. - - -
	04. - - -
	05. - - -

CONSULTANT:	NOTES
	THIS DRAWINGS SHALL BE READ IN CONJUNCTION WITH RELEVANT ARCHITECTURAL, PLUMBING, ELECTRICAL AND MECHANICAL DRAWINGS

COPYRIGHT:	REMARKS

SHEET NO:
E-04

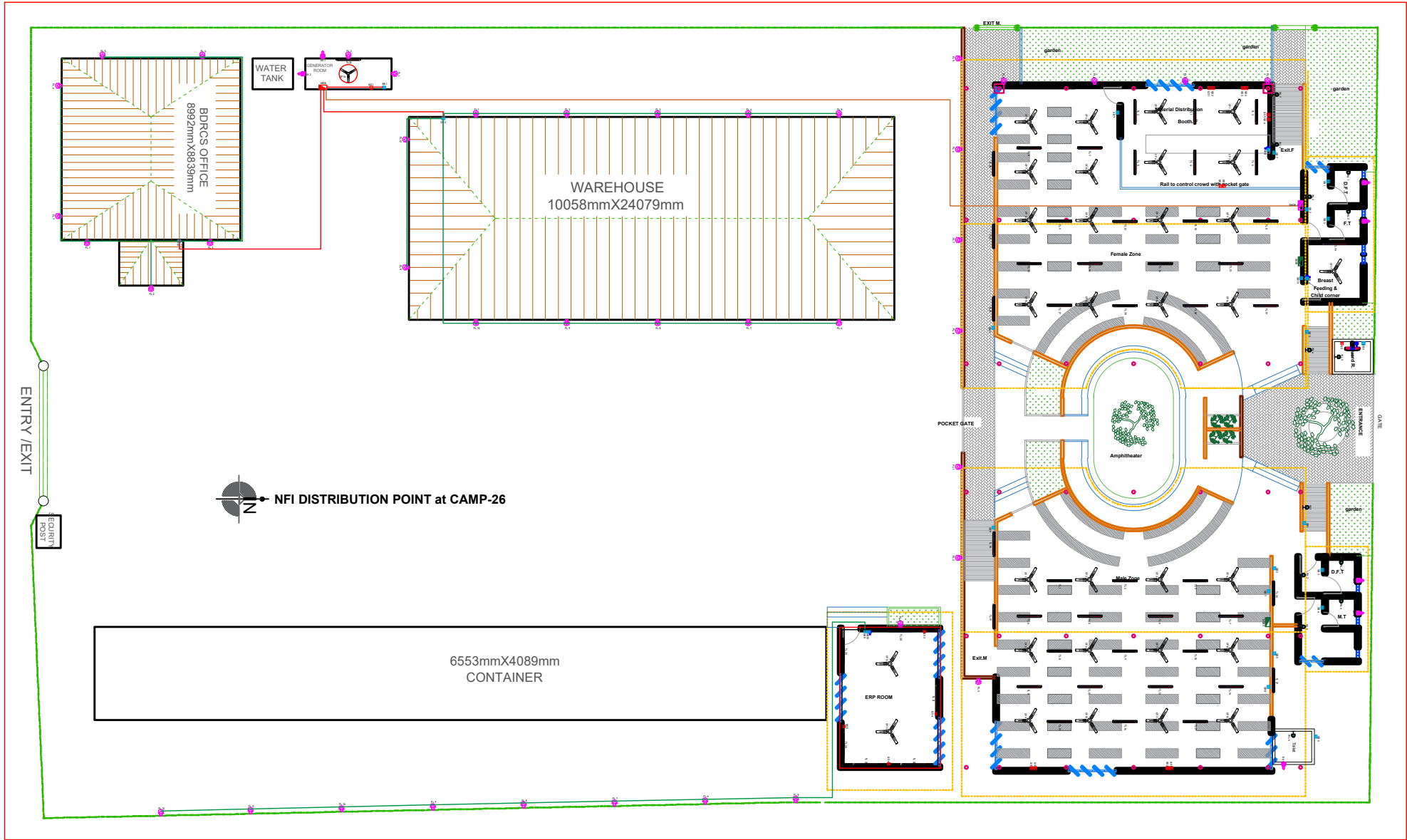

NFI DISTRIBUTION POINT at CAMP-26

CLIENT :	PROJECT NAME
UNHCR	ELECTRICAL DESIGN OF NFI DISTRIBUTION POINT
PROJECT ADDRESS :	SCALE:
CAMP-26, UKHIYA, COX'S BAZAR	NOT IN SCALE

PARTICULARS	NAME	SIGNATURE

DRAWING TITLE	DATE
FULL ELECTRICAL LAYOUT	04-DEC-2025

NO.	DATE & TIME	DESCRIPTION
01.	-	-
02.	-	-
03.	-	-
04.	-	-
05.	-	-

CONSULTANT:	REVISION

NOTES :	COPYRIGHT:
THIS DRAWINGS SHALL BE READ IN CONJUNCTION WITH RELEVANT ARCHITECTURAL, PLUMBING, ELECTRICAL AND MECHANICAL DRAWINGS	

REMARKS	SHEET NO.
	E-05

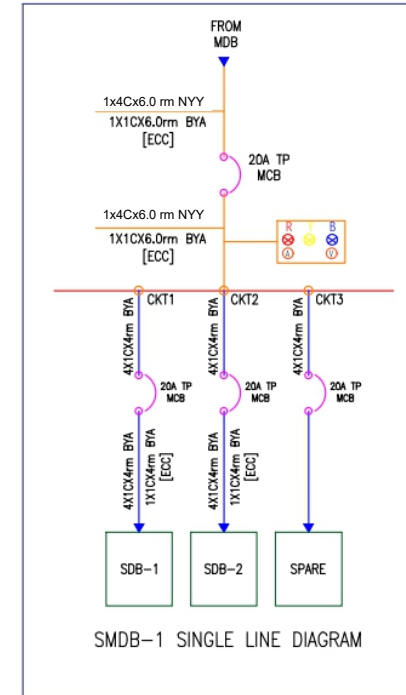
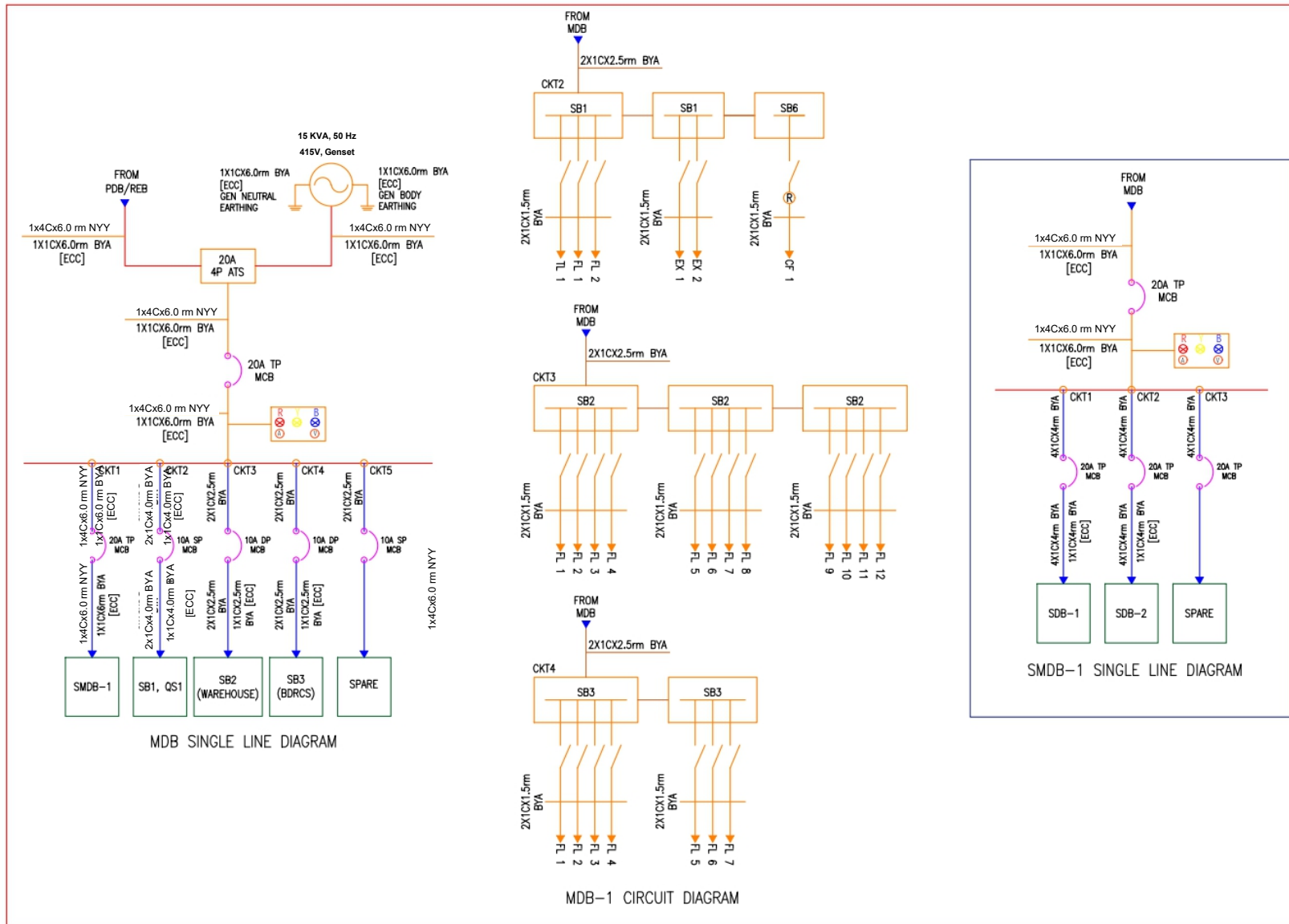

CLIENT UNHCR	PROJECT NAME ELECTRICAL DESIGN OF NTI DISTRIBUTION POINT	PARTICULARS	DATE 04-DEC-2025	REVISION NO. DATE NAME DESCRIPTION	ED-GRA.F.A.H	NOTES THIS DRAWINGS SHALL BE READ IN CONJUNCTION WITH RELEVANT STRUCTURAL PLUMBING, ELECTRICAL AND MECHANICAL DRAWINGS	COPYRIGHT	REVISIONS	SHEET NO E-06
PROJECT ADDRESS CAMP-26, UKHTYA, COX'S BAZAR	SCALE NOT IN SCALE								

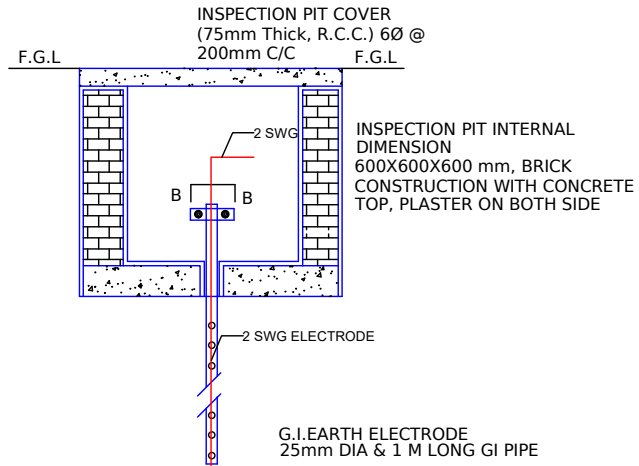

INSPECTION PIT GROUND ROD
FOR SYSTEM EARTHING.

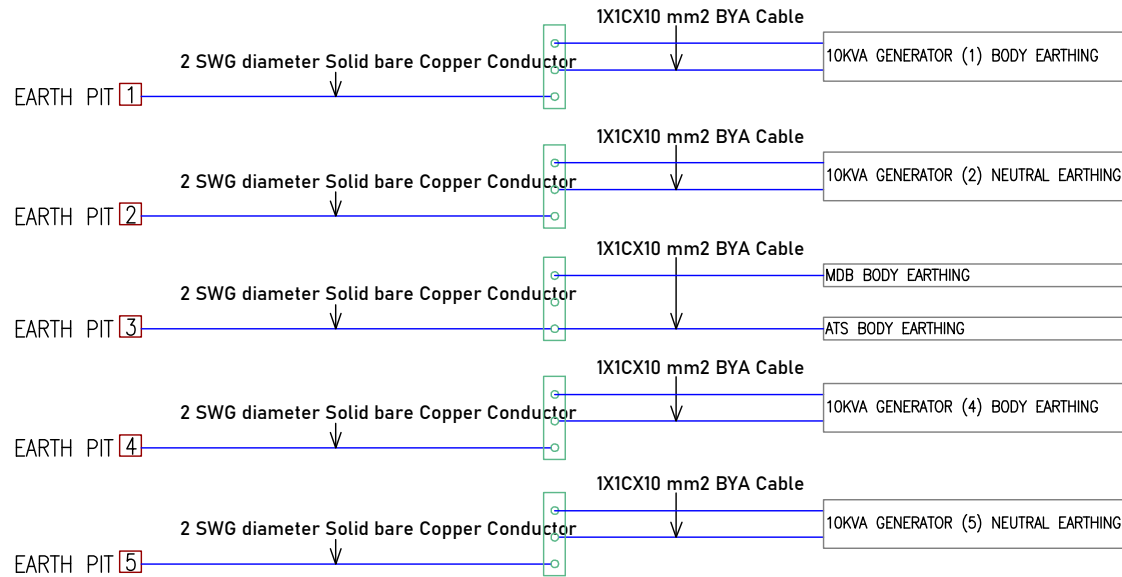

Earthing Layout Drawing

CLIENT :	PROJECT NAME :	PARTICULARS :	NAME :	SIGNATURE :	DRAWING TITLE :	REVISION NO. :	DATE & TIME :	DESCRIPTION :	CONSULTANT :	- NOTES -	- COPYRIGHT -	REMARKS :	SHEET NO. :
UNHCR	ELECTRICAL DESIGN OF NFI DISTRIBUTION POINT				EARTHING DETAILS	01.				THIS DRAWINGS SHALL BE READ IN CONJUNCTION WITH RELEVANT ARCHITECTURAL PLUMBING, ELECTRICAL AND MECHANICAL DRAWINGS			E-09
PROJECT ADDRESS :	SCALE :				DATE :	02.	-	-					
CAMP-26, UKHIYA, COX'S BAZAR	NOT IN SCALE				04-DEC-2025	03.	-	-					
						04.	-	-					
						05.	-	-					

PROJECT:

**ELECTRICAL DESIGN OF NFI DISTRIBUTION
POINT**

Location:

Camp-26, Ukhiya, Cox's Bazar.

Date of Submission:

December 04, 2025

Drawing Title:

LPS DRAWING

RISK INDEX ASSESSMENT AS PER BNBC 2006

INDEX	TITLE	DETAILS	POINTS
A	USE OF STRUCTURE	Office block	7
B	TYPE OF CONTRUCTION	Metal Roof	5
C	CONTENTS OR CONSEQUENTIAL EFFECTS	Not containing valuable materials	2
D	DEGREE OF ISOLATION	Structure located in a large area having structures or trees of similar or greater height, e.g. a large town or forest	2
E	TYPE OF TERRAIN	Hilly terrain	6
F	HIGHT OF STRUCTURE	Up to 9 m	2
G	LIGHTNING PREVALENCE	Over 21	21
	THE SUM OF INDEX		45
	MARGINAL RISK INDEX		40
	REMARKS	LIGHTNING PROTECTION IS REQUIRED	

CLIENT: UNHCR	PROJECT NAME: ELECTRICAL DESIGN OF NFI DISTRIBUTION POINT	PARTICULARS	NAME	SIGNATURE	DRAWING TITLE: RISK INDEX	REVISION	CONSULTANT:	NOTES: THIS DRAWINGS SHALL BE READ IN CONJUNCTION WITH RELEVANT ARCHITECTURAL, PLUMBING, ELECTRICAL AND MECHANICAL DRAWINGS	COPYRIGHT:	REMARKS	SHEET NO. LPS-01																	
PROJECT ADDRESS: CAMP-26, UKHIYA, COX'S BAZAR	SCALE: NOT IN SCALE				DATE: 04-DEC-2025	<table border="1" style="width: 100%; border-collapse: collapse;"> <thead> <tr> <th>NO.</th> <th>DATE & TIME</th> <th>DESCRIPTION</th> </tr> </thead> <tbody> <tr><td>01.</td><td>-</td><td>-</td></tr> <tr><td>02.</td><td>-</td><td>-</td></tr> <tr><td>03.</td><td>-</td><td>-</td></tr> <tr><td>04.</td><td>-</td><td>-</td></tr> <tr><td>05.</td><td>-</td><td>-</td></tr> </tbody> </table>	NO.	DATE & TIME	DESCRIPTION	01.	-	-	02.	-	-	03.	-	-	04.	-	-	05.	-	-				
NO.	DATE & TIME	DESCRIPTION																										
01.	-	-																										
02.	-	-																										
03.	-	-																										
04.	-	-																										
05.	-	-																										

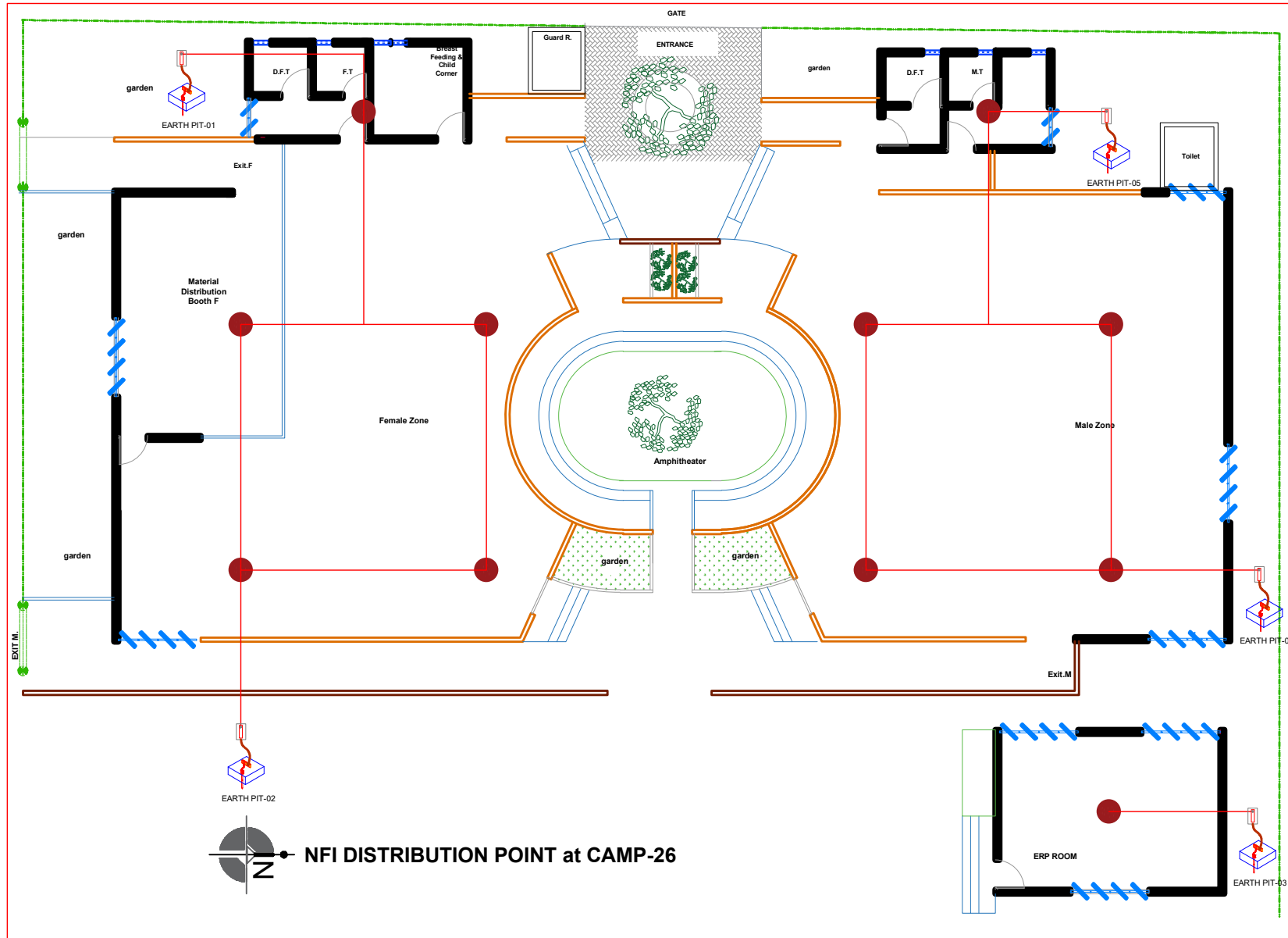

NFI DISTRIBUTION POINT at CAMP-26

CLIENT UNHCR	PROJECT NAME ELECTRICAL DESIGN OF NFI DISTRIBUTION POINT	PARTICULARS	NAME	SIGNATURE	DRAWING TITLE LPS LAYOUT	REVISION SNO. DATE & TIME DESCRIPTION	CONSULTANT	NOTES THIS DRAWINGS SHALL BE READ IN CONJUNCTION WITH RELEVANT ARCHITECTURAL, PLUMBING, ELECTRICAL AND MECHANICAL DRAWINGS	COPYRIGHT	REMARKS	SHEET NO. LPS-02
PROJECT ADDRESS CAMP-26, UKHIYA, COX'S BAZAR	SCALE NOT IN SCALE				DATE 04-DEC-2025	01. - - 02. - - 03. - - 04. - - 05. - -					

DESIGN STANDARD : NFPA 780, EDITION 2014

LEGEND	
Symbol	Explanation
	Air Terminal
	Roof & Down Conductor
	Grounding Electrode

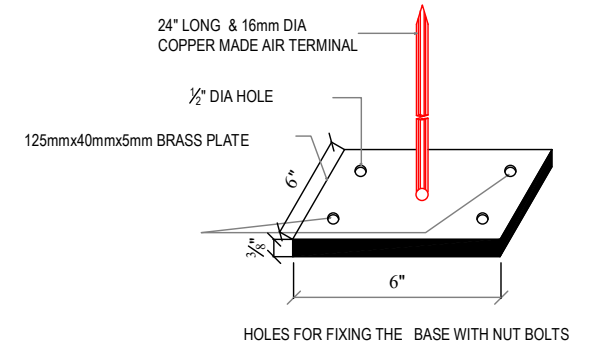
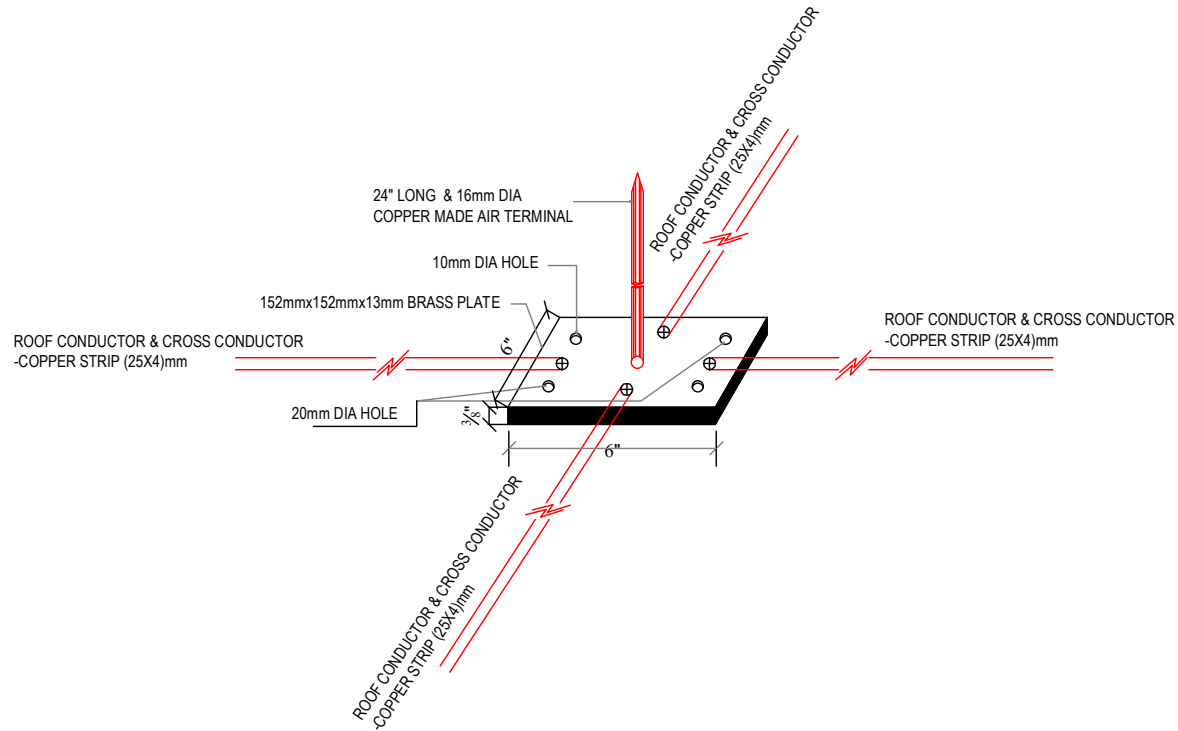
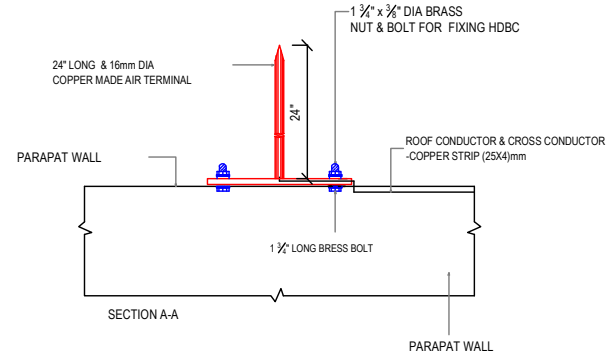

CLIENT :	PROJECT NAME :	PARTICULARS :	NAME :	SIGNATURE :	DRAWING TITLE :	REVISION :	CONSULTANT :	NOTES :	COPYRIGHT :	REMARKS :	SHEET NO. :
UNHCR	ELECTRICAL DESIGN OF NF1 DISTRIBUTION POINT				AIR TERMINAL DETAILS	NO. DATE & TIME DESCRIPTION		THIS DRAWINGS SHALL BE READ IN CONJUNCTION WITH RELEVANT ARCHITECTURAL, PLUMBING, ELECTRICAL AND MECHANICAL DRAWINGS			LPS-03
PROJECT ADDRESS :	SCALE :				DATE :	01. - -					
CAMP-26, UKHIYA, COX'S BAZAR	NOT IN SCALE				04-DEC-2025	02. - -					
						03. - -					
						04. - -					
						05. - -					

DESIGN STANDARD : NFPA 780, EDITION 2014

LEGEND	
Symbol	Explanation
	Air Terminal
	Roof & Down Conductor
	Grounding Electrode

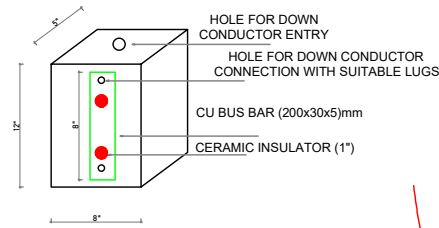

EARTH RESISTANCE TEST POINT

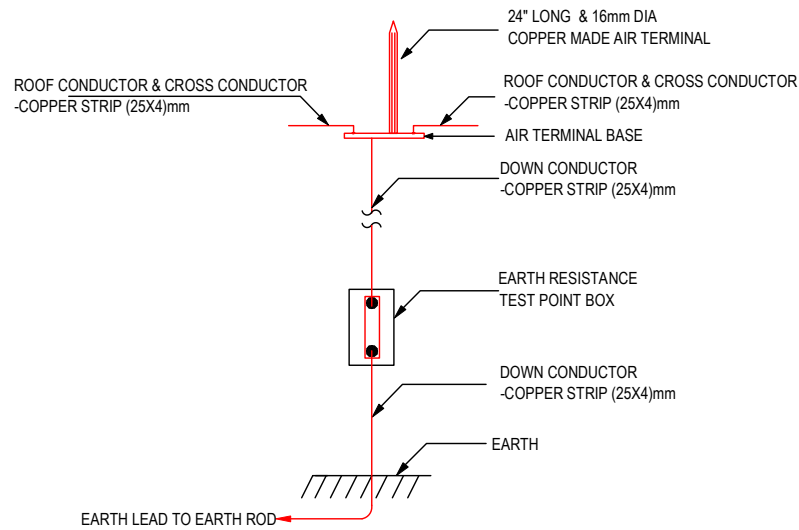
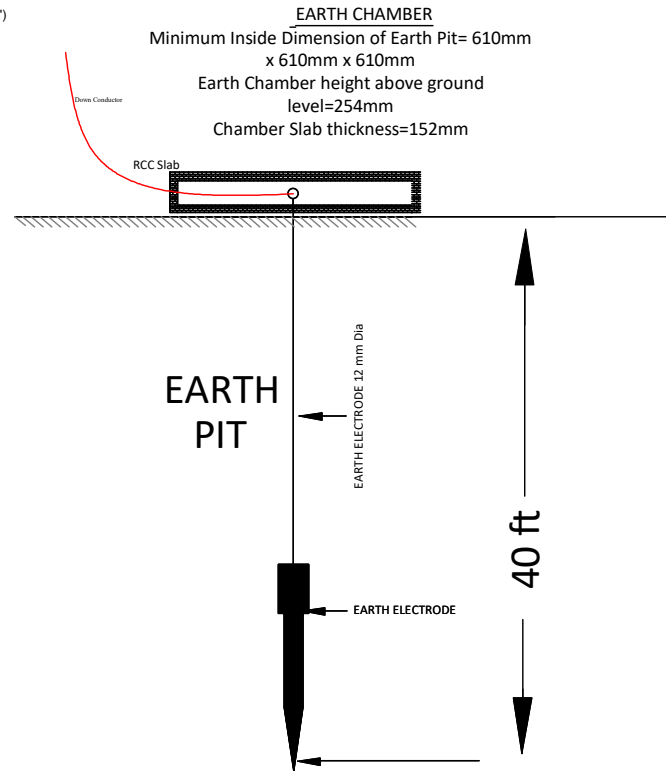

CLIENT: UNHCR	PROJECT NAME: ELECTRICAL DESIGN OF NFI DISTRIBUTION POINT	PARTICULARS:	NAME:	SIGNATURE:	DRAWING TITLE: LPS EARTHING DETAILS	REVISION: NO. DATE & TIME: DESCRIPTION:	CONSULTANT:	NOTES: THIS DRAWINGS SHALL BE READ IN CONJUNCTION WITH RELEVANT ARCHITECTURAL, PLUMBING, ELECTRICAL AND MECHANICAL DRAWINGS	COPYRIGHT:	REMARKS:	SHEET NO: LPS-04
PROJECT ADDRESS: CAMP-26, UKHIYA, COX'S BAZAR	SCALE: NOT IN SCALE				DATE: 04-DEC-2025	01. - - - 02. - - - 03. - - - 04. - - - 05. - - -					

PROJECT:

**ELECTRICAL DESIGN OF NFI DISTRIBUTION
POINT**

Location:

Camp-26, Ukhiya, Cox's Bazar.

Date of Submission:

December 04, 2025

Drawing Title:

FIRE DRAWING

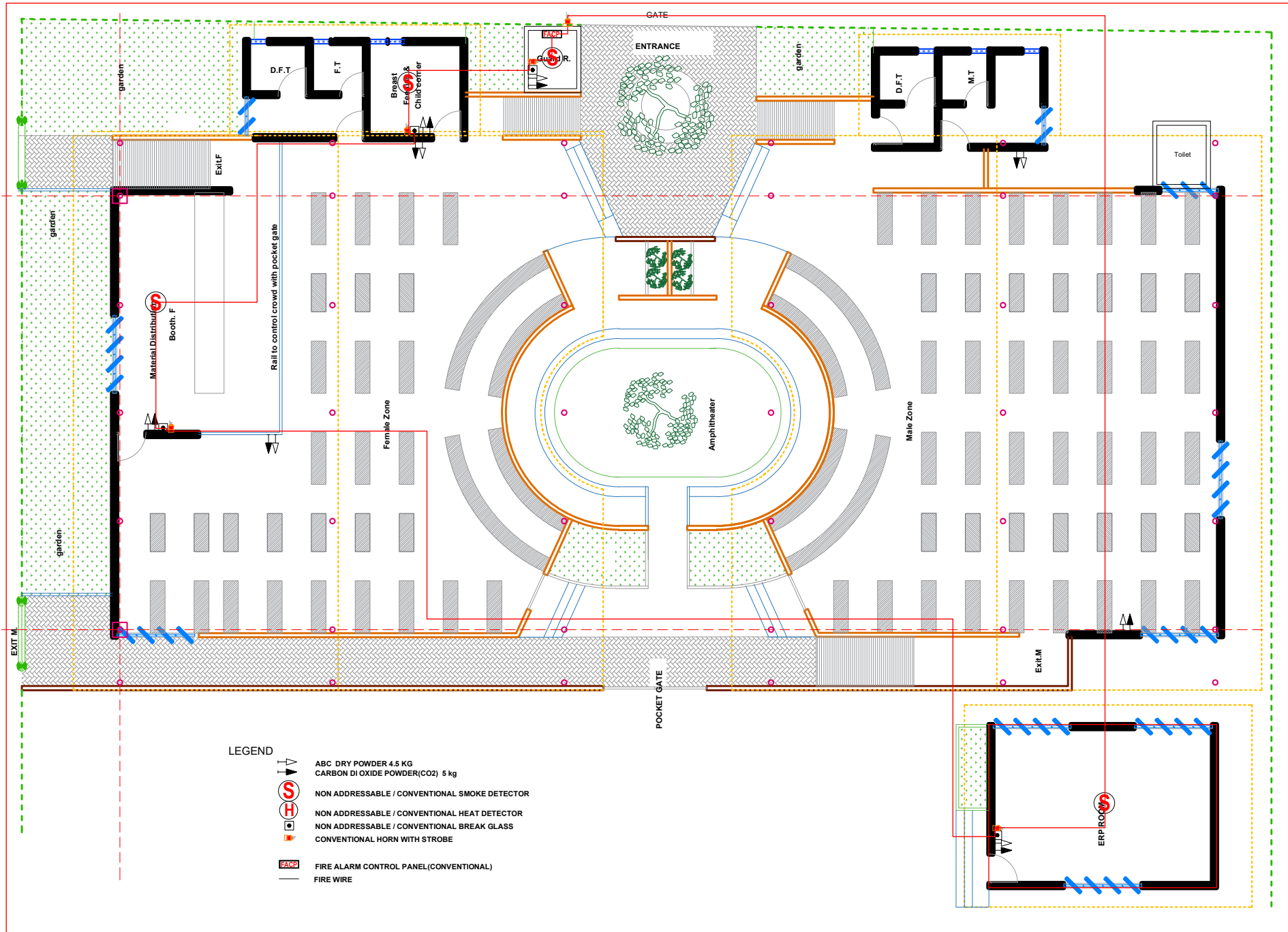

- LEGEND**
- ABC DRY POWDER 4.5 KG
 - CARBON DIOXIDE POWDER(CO2) 5 kg
 - NON ADDRESSABLE / CONVENTIONAL SMOKE DETECTOR
 - NON ADDRESSABLE / CONVENTIONAL HEAT DETECTOR
 - NON ADDRESSABLE / CONVENTIONAL BREAK GLASS
 - CONVENTIONAL HORN WITH STROBE
 - FIRE ALARM CONTROL PANEL(CONVENTIONAL)
 - FIRE WIRE

CLIENT: UNHCR	PROJECT NAME: ELECTRICAL DESIGN OF NFI DISTRIBUTION POINT	PARTICULARS	NAME:	SIGNATURE:	DRAWING TITLE: FIRE DESIGN	REVISION NO. DATE & TIME: DESCRIPTION	CONSULTANT:	-NOTES- THIS DRAWINGS SHALL BE READ IN CONJUNCTION WITH RELEVANT ARCHITECTURAL, PLUMBING, ELECTRICAL AND MECHANICAL DRAWINGS	-COPYRIGHT-	REMARKS	SHEET NO. F-01
PROJECT ADDRESS: CAMP-26, UKHIYA, COX'S BAZAR	SCALE: NOT IN SCALE				DATE: 04-DEC-2025	01. - - 02. - - 03. - - 04. - - 05. - -					